

FILTER
FILTR XF MINI
FILTRO

XFO

PAGE
3.06



COALESCER FILTERS
FILTR XC MINI
FILTRO A COALESCENZA

XCO

PAGE
3.07



REGULATOR
REGULÁTOR XR MIMI
REGOLATORE

XRO

PAGE
3.08



QUICK EXHAUST REGULATOR
REGULÁTOR ODFUKU XM MIMI
REGOLATORE SCARICO RAPIDO

XMO

PAGE
3.09



WATER REGULATOR
REGULÁTOR VODY XQ
REGOLATORE PER ACQUA

XQO

PAGE
3.10



FILTER REGULATOR
FILTR A REGULÁTOR XP MINI
FILTROREGOLATORE

XPO

PAGE
3.11



LUBRICATOR
MAZNICE VZDUCHU XL MINI
LUBRIFICATORE

XLO

PAGE
3.12



FILTERREGULATOR+LUBRICATOR (FR+L)
FILTR, REGULÁTOR + MAZNICE XS MINI
FILTROREGOLATORE + LUBRIFICATORE (FR+L)

XS0

PAGE
3.13



FILTER+REGULATOR+LUB. (F+R+L)
FILTR+REGULÁTOR+MAZNICE XT MINI
FILTRO + REGOLATORE + LUB. (F+R+L)

XT0

PAGE
3.14



FILTER + COALESCER FILTER
FILTR XC+XF MINI
FILTRO + FILTRO A COALESCENZA

XDO

PAGE
3.15



FILTER
FILTR XF
FILTRO

XF

PAGE
3.16



COALESCER FILTER
FILTR XC
FILTRO A COALESCENZA

XC

PAGE
3.18



REGULATORE
REGULÁTOR XR
REGOLATOR

XR

PAGE
3.19



FILTER REGULATOR
FILTR A REGULÁTOR XP
FILTRO REGULATORE

XP

PAGE
3.20



LUBRICATOR
MAZNICE VZDUCHU XL
LUBRIFICATORE

XL

PAGE
3.22



FILTERREGULATOR+LUBRICATOR (FR+L)
FILTR, REGULÁTOR + MAZNICE XS
FILTROREGOLATORE + LUBRIFICATORE (FR+L)

XS

PAGE
3.24



FILTER+REGULATOR+LUB. (F+R+L)
FILTR+REGULÁTOR+MAZNICE XT
FILTRO + REGOLATORE + LUB. (F+R+L)

XT

PAGE
3.25



SOFT START VALVE WITH QUICK EXH.
START VENTIL S RYCHLYM ODFUKEM XA
AVVIATORE PROGRESSIVO CON SCARICO R.

XA

PAGE
3.26



SHOT OFF VALVE
UZAVÍRACÍ VENTIL RUČNÍ 3/2 XV
VALVOLA SELETRICE

XV

PAGE
3.27



FILTER + LUBRICATOR (F+L)
FILTR XO
FILTRO + LUBRIFICATORE (F+L)

XO

PAGE
3.29



FILTER + COALESCER FILTER
FILTR XD
FILTRO + FILTRO A COALESCENZA

XD

PAGE
3.30



VALVE+FILTERREGULATOR+LUB. (V+FR+L)
VENTIL+FILTRREGULÁTOR+MAZNICE (V+FR+L)
VALVOLA+FILTROREGOLATORE+LUB (V+FR+L)

XM

PAGE
3.31



VALVE+FILTER+REG.+LUB. (V+F+R+L)
VENTIL+FILTR+REGULÁTOR+MAZNICE (V+F+R+L)
VALVOLA+FILTRO+REG.+LUB. (V+F+R+L)

XN

PAGE
3.32



ACCESSORIES
PŘÍSLUŠENSTVÍ
ACCESSORI

XB

PAGE
3.33



FILTER
 FILTR YF
 FILTRO

YF

PAGE
 3.41



COALESCER FILTERS
 FILTR YC
 FILTRO A COALESCENZA

YC

PAGE
 3.42



REGULATOR
 REGULÁTOR YR
 REGOLATORE

YR

PAGE
 3.43



FILTER REGULATOR
 FILTR A REGULÁTOR YP
 FILTROREGOLATORE

YP

PAGE
 3.44



LUBRICATOR
 MAZNICE VZDUCHU YL
 LUBRIFICATORE

YL

PAGE
 3.45



FILTERREGULATOR+LUBRICATOR (FR+L)
 FILTR, REGULÁTOR + MAZNICE YS (FR+L)
 FILTROREGOLATORE + LUBRIFICATORE (FR+L)

YS

PAGE
 3.46



FILTER+REGULATOR+LUB. (F+R+L)
 FILTR+REGULÁTOR+MAZNICE YT (F+R+L)
 FILTRO+REGOLATORE+LUB. (F+R+L)

YT

PAGE
 3.47



FILTER + LUBRICATOR (F+L)
 FILTR A MAZNICE VZDUCHU YO (F+L)
 FILTRO + LUBRIFICATORE (F+L)

YO

PAGE
 3.48



FILTER + COALESCER FILTER
 FILTR YD
 FILTRO + FILTRO A COALESCENZA

YD

PAGE
 3.49



DRYER
 SUŠIČKA VZDUCHU YE
 ESSICCATORE

YE

PAGE
 3.50



DRIP LEG DRAIN
 AUTOMATICKÝ ODVOD KONCENTRÁTU
 SCARICATORE AUTOMATICO DI CONDENSA

YJ

PAGE
 3.51



PILOT CONTROLLED REGULATOR
 PILOTEM ŘÍZENÝ REGULÁTOR YU
 REGOLATORE PILOTABILE

YU

PAGE
 3.52



LOCKABLE ISOLATION VALVE
 UZAMYKATELNÝ VENIL
 VALVOLA SEZIONATRICE LUCCHETTABILE

YV

PAGE
 3.53



ACCESSORIES
 PŘÍSLUŠENSTVÍ
 ACCESSORI

YB

PAGE
 3.54



Assembly size 0 / Velikost sestavy 0 / Montaggio taglia 0



Generally the assembling of FRL components has to follow this order: Filter, Regulator, Lubricator. While connecting the components, be sure that the air flows towards the direction of the arrows located on the upper surface of the components.

The setting up of the parts has to be done as follows: Put the plates in the proper places of the bodies. Put the assembling parts together, making sure that the o-ring are in their proper seats. Tighten the screws on the plates.

Obecně musí montáž komponent FRL odpovídat tomuto pořadí: Filtr, Regulátor, Maznice.

Při připojování součástí se ujistěte, že vzduch proudí ve směru šipek umístěných na horní části jednotky.

Nastavení součástí musí být provedeno následovně: Umístěte destičky na správná místa těla.

Sestavte montážní díly dohromady a ujistěte se, že o-kroužek je na svém místě. Utáhněte šrouby na deskách.

L'assemblaggio dei componenti della serie FRL deve seguire, in linea di massima, questo ordine: Filtro, Regolatore, Lubrificatore.

L'accoppiamento dei componenti deve avvenire facendo in modo che l'aria fluisca nella direzione indicata dalle frecce poste sulla superficie superiore dei componenti.

L'assemblaggio dei componenti si effettua facilmente seguendo le seguenti fasi:

- Inserire le piastrine nelle apposite sedi ricavate nei corpi.
- Accostare i componenti da assemblare, verificando la presenza delle or nelle apposite sedi.
- Serrare le viti sulle piastrine.

Regulator / Regulátor / Regolatore



To regulate the pressure follow these suggestions:

- raise the knob to the regulating position;
- fix up the required pressure always upgrade then press the knob to the block position.

Chcete-li regulovat tlak, postupujte podle těchto doporučení:

- zvedněte knoflík do regulační polohy;
- vždy upravte požadovaný tlak a potom vždy stiskněte knoflík do polohy blokování.

Per l'impostazione della pressione si devono seguire queste indicazioni:

- sollevare la manopola nella posizione di regolazione;
- Impostare la pressione voluta sempre in salita;
- premere la manopola nella posizione di blocco.

L'applicazione del manometro deve avvenire manualmente e con l'utilizzo di sigillanti liquidi.

Quick exhaust regulator / Rychlý regulátor výfuku / Regolatore di scarico rapido



The mini quick exhaust regulator allows the circuit downstream to exhaust rapidly when upstream pressure is interrupted.

Mini rychlý regulátor výfuku umožňuje rychlé odvádění okruhu po proudu když je tlak ve směru proudění přerušen.

Il regolatore a scarico rapido permette di scaricare rapidamente il circuito a valle all'annullarsi della pressione a monte.

Lubricator / Maznice / Lubrificatore

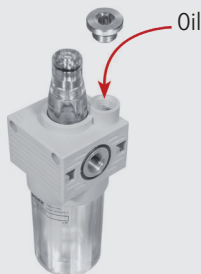

To insert the oil into the lubricator unscrew the plug located on the upper surface or Disassemble the bowl making sure that there is no pressure in the system. To regulate the oil into the circuit act with a screwdriver on the needle and adjust 1 oil drop every 300/600 NI/min.

Chcete-li vložit olej do maznice, odšroubujte zátku umístěnou na horní ploše nebo demontujte misku a ujistěte se, že v systému není žádný tlak. K regulaci oleje do okruhu se provádí regulačním šroubem a upravovat 1 kapku oleje každých 300/600 NI / min.

L'inserimento dell'olio nel lubrificatore si effettua svitando il tappo posto sulla superficie superiore oppure smontando la tazza accertandosi prima che non vi sia pressione nell'impianto. La regolazione dell'olio nel circuito si effettua agendo con un cacciavite sullo spillo e impostando una goccia di olio ogni 300-600 NI/min.

Filter / Filtr / Filtro



The manual/semiautomatic condensate exhaust is normally in the open position; i.e. it exhausts automatically the condensate when there is no pressure inside the bowl. Pressing the knob it is possible to exhaust the condensate even if it is on pressure, turning the knob in anticlockwise sense the exhaust is in the close position.

Ruční / poloautomatický odvod kondenzátu je normálně v otevřené poloze; tj. automaticky vyčerpá kondenzát když uvnitř nádoby není žádný tlak. Stisknutím knoflíku je možné kondenzát vypustit, i když je pod tlakem, otočením knoflíku proti směru hodinových ručiček je výfuk v uzavřené poloze.

Lo scarico della condensa Manuale / Semiautomatico è normalmente nella posizione aperta cioè scarica automaticamente la condensa quando è assente la pressione nella tazza, premendo la manopola è possibile scaricare la condensa in presenza di pressione, ruotando la manopola in senso antiorario lo scarico è nella posizione chiusa.

Assembly size 1-2-3 / Velikost sestavy 1-2-3 / Montaggio taglia 1-2-3

The setting up of the parts has to be done as follows:
Put the plates in the proper places of the bodies. Put the assembling parts together, making sure that the O-ring are in their proper seats. Tighten the screws on the plates.

**Sestavení součástí musí být provedeno následovně:
Umístěte talíře na správná místa těla. Sestavte montážní díly dohromady a ujistěte se, že O-kroužek je v jejich na sedle. Utáhněte šrouby na deskách.**

*L'assemblaggio dei componenti della serie FRL deve seguire, in linea di massima, questo ordine:
Valvola sezionatrice, Filtro, Regolatore, Lubrificatore e Avviatore progressivo.*

L'accoppiamento dei componenti deve avvenire facendo in modo che l'aria fluisca nella direzione indicata dalle frecce poste sulla superficie superiore dei componenti.

Regulator / Regulátor / Regolatore

To regulate the pressure follow these suggestions:

- raise the knob to the regulating position;
- fix up the required pressure always upgrade then press the knob to the block position. The manometer has to be assembled manually with the addition of liquid sealant.

Chcete-li regulovat tlak, postupujte podle těchto doporučení:

**- zvedněte knoflík do regulační polohy;
- Opravte požadovaný tlak vždy aktualizujte a poté stiskněte knoflík do polohy bloku. Manometr musí být připevněn ručně s těsněním závitu.**

Per l'impostazione della pressione si devono seguire queste indicazioni:

*- sollevare la manopola nella posizione di regolazione;
- impostare la pressione voluta sempre in salita;
- premere la manopola nella posizione di blocco.*

L'applicazione del manometro deve avvenire manualmente e con l'utilizzo di sigillanti liquidi.

Filter / Filtr / Filtro

The manual/semiautomatic condensate exhaust is normally in the open position; i.e. it exhausts automatically the condensate when there is no pressure inside of the bowl. Pressing the knob it is possible to exhaust the condensate even if it is on pressure, turning the knob in anticlockwise sense the exhaust is in the close position.

The automatic condensate exhaust is available for the sizes FRL2 and FRL3. It works

As a float that exhausts the condensate when this reaches the programmed level without any relation to the pressure used.

Ruční / poloautomatický odvod kondenzátu je normálně v otevřené poloze; tj. vypouští automaticky kondenzát když uvnitř nádoby není žádný tlak. Stisknutím knoflíku je možné kondenzát vypustit, i když je pod tlakem, otočením knoflíku proti směru hodinových ručiček je výfuk v uzavřené poloze.

Automatický odvod kondenzátu je k dispozici pro velikosti FRL2 a FRL3. Funguje to jako plovák, který vyčerpává kondenzát.

Lo scarico della condensa Manuale / Semiautomatico è normalmente nella posizione aperta cioè scarica automaticamente la condensa quando è assente la pressione nella tazza, premendo la manopola è possibile scaricare la condensa in presenza di pressione, ruotando la manopola in senso antiorario lo scarico è nella posizione chiusa. Lo scarico di condensa automatico è disponibile per le misure FRL2 e FRL3. Il suo funzionamento è di tipo a galleggiante cioè scarica la condensa quando questa raggiunge il livello impostato indipendentemente dalla pressione di utilizzo.

Lubricator / Maznice / Lubrificatore

To insert the oil into the lubricator, unscrew the plug on the upper surface or disassemble the bowl making sure that no pressure is in the system. To regulate the oil into the circuit act the needle with a screwdriver and adjust 1 oil drop every 300/600NI/min.

The priming of vacuum permits the automatic filling in the bowl. Pushing the start button starts the driving of the system. The oil, collected from a level lower than lubricator, flows into the bowl thanks to a fitting G 1/4 located under the bowl. Stop the priming when the oil has reached the maximum level allowed. This level corresponds with the transparent windows in the bowl.

Chcete-li vložit olej do maznice, odšroubujte zátku na horní ploše nebo odšroubujte nádobku, u které nesní být žádný tlak. Pro regulaci oleje do okruhu použijte jehlu pomocí šroubováku a seřídte 1 kapku oleje na každých 300/600 NI / min.

Vakuové plnění oleje umožňuje automatické plnění oleje v nádobce. Stisknutím tlačítka start se spustí řízení systému. Olej, samovolně, protéká do misky díky fitinku G 1/4 umístěné pod miskou. Zastavte plnění jakmile olej dosáhne maximální povolené hladiny. Tato úroveň odpovídá průhledným oknům v misce.

L'inserimento dell'olio nel lubrificatore si effettua svitando il tappo posto sulla superficie superiore oppure smontando la tazza accertandosi prima che non vi sia pressione nell'impianto. La regolazione dell'olio nel circuito si effettua agendo con un cacciavite sullo spillo e impostando una goccia di olio ogni 300-600 NI/min.

Il caricamento dell'olio a depressione consente il riempimento in automatico di olio nella tazza.

Il sistema si attiva mediante l'azionamento di un pulsante e l'olio prelevato da un serbatoio posto anche a quote più basse rispetto al lubrificatore fluisce nella tazza grazie ad un attacco G1/4 posto sotto di essa. Il caricamento deve essere interrotto quando l'olio raggiunge il livello massimo consentito corrispondente alle aperture trasparenti della tazza.

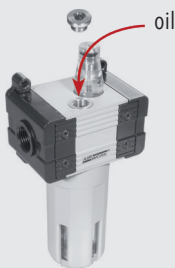

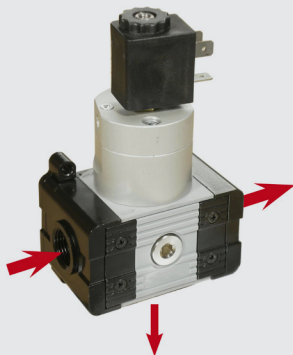
Soft start valve with quick exhaust / start ventil s rychlým odfukem / Avvitatore progressivo con scarico rapido

The soft start valve is a pneumatic valve that permits to pressurize gradually and constantly the pneumatic systems. The quick exhaust is present on our soft starter; by switching off the electrical signal it stops the air-intake, exhausting the remaining air downstream.

To regulate the pressure increasing time use a screw. An electrical impulse gives power to the starter. Install the starter on the system just after the components for air treatment.

Start ventil je pneumatické zařízení, které umožňuje natlakovat systémy postupně a nastavitelným způsobem pneumatiky. Rychlý odtok je integrovaná funkce přítomná v našem start ventilu, takže je možné zastavit průtok vzduchu, přerušující elektrický signál pilota a rychle vypouštějí zbytkový vzduch v následném systému do vnějšího prostředí. Čas zvýšení tlaku je regulován nastavením speciálního šroubu, který zasahuje o regulaci průtoku.

Pilotní příkaz je elektropneumatický: progresivní startér pracuje pomocí elektrického impulsu.

Měkký startér s rychlým vypouštěním musí být umístěn v systémové lince po všech součástech ošetřování

L'avvitatore progressivo è un dispositivo pneumatico che consente di pressurizzare gradualmente e in modo regolabile gli impianti pneumatici. Lo scarico rapido è una funzione integrata presente nel nostro avvitatore progressivo quindi è possibile interrompere l'afflusso di aria, interrompendo il segnale elettrico del pilota, e scaricare rapidamente l'aria residua nell'impianto di valle nell'ambiente esterno. La regolazione del tempo dell'incremento della pressione avviene mediante la registrazione di un'apposita vite che interviene sulla regolazione del flusso.

Il comando di pilotaggio è elettropneumatico: il funzionamento dell'avvitatore progressivo avviene mediante un impulso elettrico.

L'avvitatore progressivo con scarico rapido va posizionato nella linea dell'impianto dopo tutti componenti di trattamento dell'aria compressa.

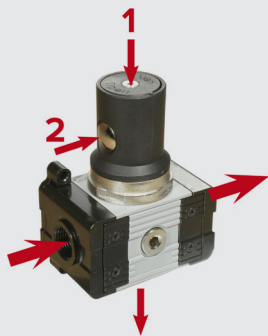
Shot off valve / uzavírací ventil ruční 3/2 / Valvola sezionatrice

The driving of the shut off valve follows these steps: pressing the start push button 1 you open the primary circuit towards the use; pressing the push button 2 you close the primary circuit and put the secondary one in exhaust. A padlock can lock this last operation.

Ovládání uzavíracího ventilu se řídí těmito kroky: stisknutím spouštěcího tlačítka 1 otevřete primární obvod k použití; stisknutím tlačítka 2 uzavřete primární obvod a dejte sekundární výfuk. Tuto poslední operaci může uzamknout zámek

L'azionamento della valvola sezionatrice avviene nelle seguenti fasi: premendo il pulsante di azionamento 1 si apre il circuito primario verso l'utilizzo, premendo il pulsante 2 si chiude il circuito primario e si mette a scarico quello secondario. Quest'ultima posizione può essere bloccata mediante lucchetto.



TECHNICAL DATA / TECHNICKÁ DATA / DATI TECNICI

Fluid / Tekutina / Fluido	Air / Vzduch / Aria
Maximum pressure / Maximální tlak / Pressione	Max 15 bar
Temperature / Teplota / Temperatura	-10° C / +50° C
Filtration grade / Filtrační schopnost / Grado di filtrazione	5 - 20 - 50µm
6bar flow rate with Δp 1bar / Průtok 6bar s Δp 1bar / Portata a 6 bar con Δp 1bar	800 NI/min
Bowl capacity / Kapacita nádoby / Capacità tazza	17,5cm ³

STANDARD PRODUCTS / STANDARDNÍ VÝROBKY / PRODOTTI STANDARD

Code Kód Codice	Size Velikost Taglia	Thread Závit Filetto	Filtration Filtrace Filtrazione	Flow rate Průtok Portata	Exhaust Odvod koncentráту Scarico
XF0121	0	1/8	20µm	800NI/min	S/M
XF0221	0	1/4	20µm	800NI/min	S/M

S/M: Semi-automatic / Manual / Poloautomatický / manuální / Semiautomatico / Manuale

ORDERING CODE / OBJEDNÁVKOVÝ KÓD / CHIAVE DI CODIFICA

X F 0 0 0 1

Filtration grade / Filtrace / Grado di filtrazione

- 1= 5 µm
- 2= 20 µm STANDARD
- 3= 50 µm

Thread / Závit / Filetto

- 1=G 1/8
- 2=G 1/4

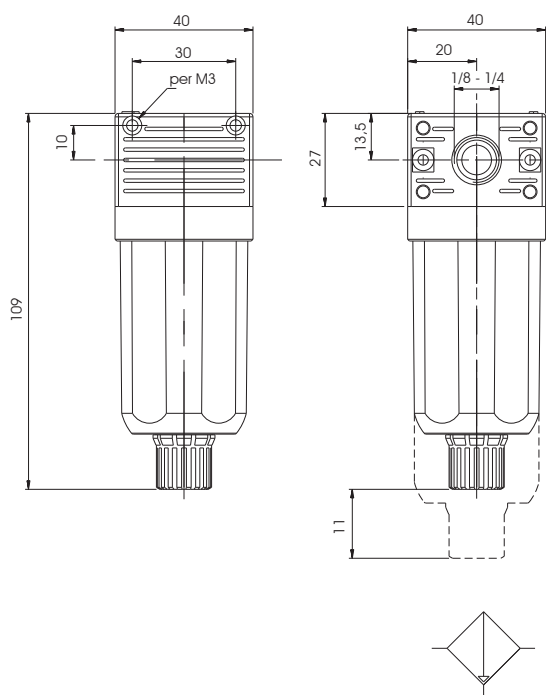

COMPONENTS / KOMPONENTY / COMPONENTI

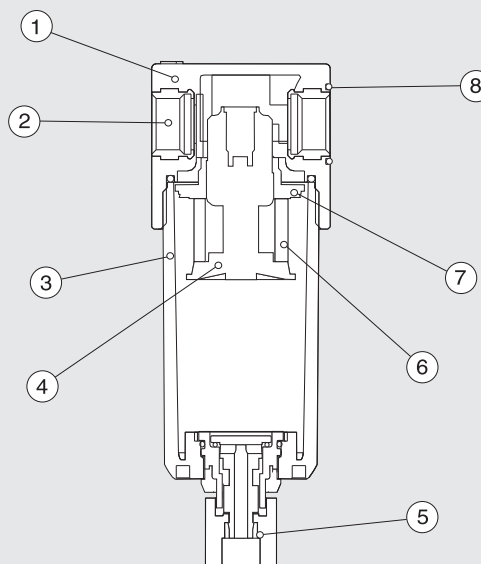

1	body / tělo / corpo	polymer / polymer / polimero
2	threaded insert / závit / inserto filettato	brass / bress / ottone
3	bowl / nádoby / tazza	polymer / polymer / polimero
4	filter ring / filtrační kroužek / portafiltro	polymer / polymer / polimero
5	condensate exhaust / Vypouštění kondenzátu	polymer / polymer / polimero
6	filtering cartridge / filtrační kazeta / cartuccia filtrante	PE
7	slinger / odšťikovací kroužek / centrifugatore	polymer / polymer / polimero
8	o-ring / O-kroužek / o-ring	NBR



TECHNICAL DATA / TECHNICKÁ DATA / DATI TECNICI

Fluid / Tekutina / Fluido	5µm filtrační kroužekd air / 5µm filtrovaného vzduchu / Aria filtrata a 5µm
Maximum pressure / Maximální tlak / Pressione	15 bar
Temperature / Teplota / Temperatura	-10° C / +50° C
Filtration grade / Filtrační schopnost / Grado di filtrazione	0.01µm
6 bar flow rate with Δp 1bar / Průtok 6 barů s Δp 1bar / Portata a 6 bar con Δp 1bar	450 NI/min
Bowl capacity / Kapacita nádoby / Capacità tazza	17,5cm ³

STANDARD PRODUCTS / STANDARDNÍ VÝROBKY / PRODOTTI STANDARD

Code Kód Codice	Size Velikost Taglia	Thread Závit Filetto	Filtration Filtrace Filtrazione	Flow rate Průtok Portata	Exhaust Odvod koncentrátu Scarico
XC0101	0	1/8	0.01µm	450NI/min	S/M
XC0201	0	1/4	0.01µm	450NI/min	S/M

S/M: Semi-automatic / Manual / Polautomatický / manuální / Semiautomatico / Manuale

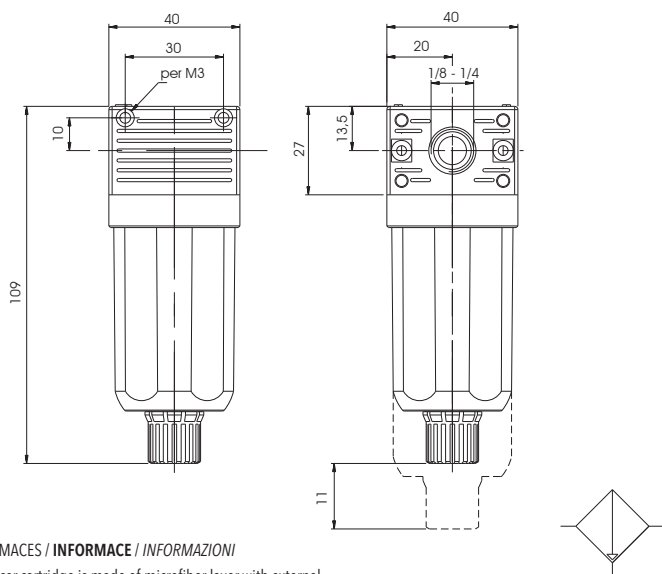

COMPONENTS / KOMPONENTY / COMPONENTI

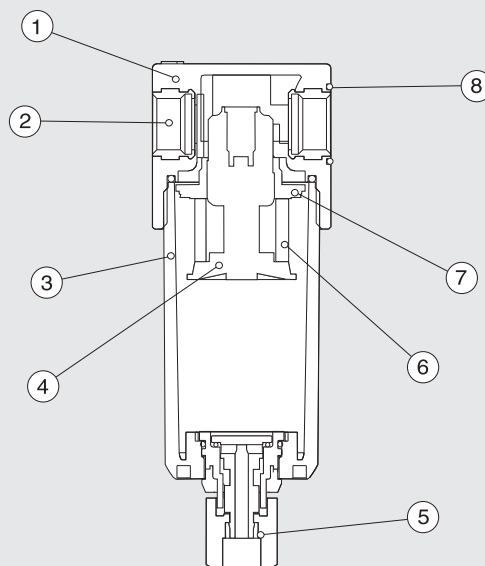

1	body / tělo / corpo	polymer / polymer / polimero
2	threaded insert / závit / inserto filettato	brass / bress / ottone
3	bowl / nádoba / tazza	polymer / polymer / polimero
4	filter ring / filtrační kroužek / portafiltro	polymer / polymer / polimero
5	condensate exhaust / Vypouštění kondenzátu	polymer / polymer / polimero
6	filtering cartridge / filtrační kazeta / cartuccia filtrante	PE
7	slinger / odšťikovací kroužek / centrifugatore	polymer / polymer / polimero
8	o-ring / O-kroužek / o-ring	NBR

INFORMACES / INFORMACE / INFORMAZIONI

Coalescer cartridge is made of microfiber layer with external stainless steel structure. Coalescing cartridge uses inertial impact, interception and coalescence to gather liquid particles into drops. These drops will fall into bowl bottom. Coalescing Filter is used as Oil Separator which removes oilvapours from air output. We recommend to install a 5 µm filter upstream to protect coalescing filter from choking of cartridge.

Koalescenční kazeta je vyrobena z mikrovlákna s vnější vrstvou nerezová konstrukce. Koalescenční kazeta používá inerciální dopad, zachycování a koalescence pro shromažďování kapaliny částice do kapek. Tyto kapky padnou na dno mísy. Koalescenční filtr se používá jako odlučovač oleje, který odstraňuje olejové kapky z výstupu vzduchu. Doporučujeme nainstalovat 5 µm filtr proti proudu pro ochranu koalescenčního filtru před zdušením kazety.

La cartuccia a coalescenza è costituita da uno strato di microfibre sorrette da una struttura esterna in acciaio inox. La cartuccia a coalescenza, sfruttando i principi dell'impatto inerziale, dell'intercettazione e della coalescenza, obbliga le particelle di liquido che l'attraversano ad unirsi formando microgocce più grandi che, per gravità, precipitano sul fondo del contenitore. Il filtro a coalescenza usato come disoleatore permette di ottenere un'aria in uscita priva di olio. Si consiglia di montare a monte del filtro a coalescenza un filtro da 5 µm che trattenga le particelle solide evitando così l'intasamento della cartuccia a coalescenza.

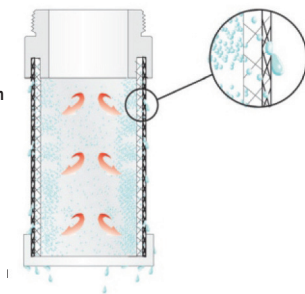



TECHNICAL DATA / TECHNICKÁ DATA / DATI TECNICI

Fluid / Tekutina / Fluido	Air / Vzduch / Aria
Maximum pressure / Maximální tlak / Pressione	15 bar
Temperature / Teplota / Temperatura	-10° C / +50° C
Regulation range / Regulační rozsah / Campo di regolazione	0-2bar 0-4bar 0-8bar standard 0-12bar
6 bar flow rate with Δp 1bar / Průtok 6 barů s Δp 1bar / Portata a 6 bar con Δp 1bar	600Nl/min
Manometer fastening / Upevnění manometrem / Attacco manometro	1/8

ORDERING CODE / OBJEDNÁVKOVÝ KÓD / CHIAVE DI CODIFICA

X R 0 0 0 0

- Regulation range / Regulační rozsah / Campo di regolazione
1= 0-2bar
2= 0-4bar
3= 0-8bar STANDARD
4= 0-12bar
- Thread / Závít / Filetto
1= G 1/8
2= G 1/4

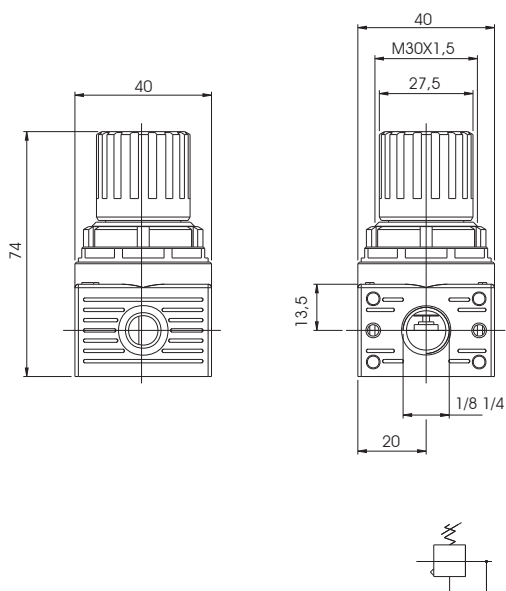

COMPONENTS / KOMPONENTY / COMPONENTI

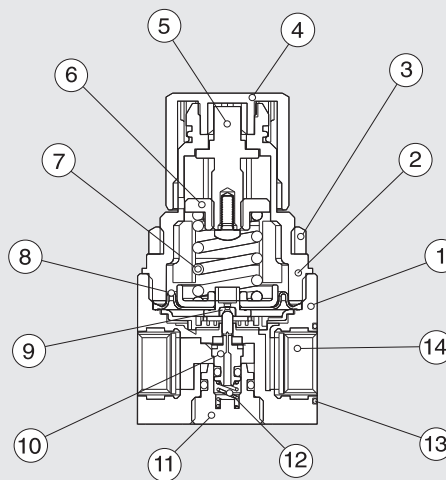

- | | | |
|----|--|---|
| 1 | body / tělo / corpo | polymer / polymer / polimero |
| 2 | bell / zvon / campana | polymer / polymer / polimero |
| 3 | fixing nut / upevňovací matice / ghiera di fissaggio | polymer / polymer / polimero |
| 4 | knob / knoflík / manopola | polymer / polymer / polimero |
| 5 | register screw / stavěcí šroub / vite di registro | brass / bress / ottone |
| 6 | female screw / samice šroub / chiocciola | brass / bress / ottone |
| 7 | register spring / pružina / molla di registro | steel / acier / acciaio |
| 8 | membrána / membrána / membrana | |
| 9 | seal / těsnění / guarnizione | NBR |
| 10 | shutter / závěrky / otturatore | NBR |
| 11 | plug / zástrčka / tappo | polymer / polymer / polimero |
| 12 | spring / pružina / molla | stainless steel / acier inox / acciaio inox |
| 13 | o-ring / O-kroužek | NBR |
| 14 | threaded insert / závít / inserto filettato | brass / bress / ottone |



TECHNICAL DATA / TECHNICKÁ DATA / DATI TECNICI

Fluid / Tekutina / Fluido	Air / Vzduch / Aria
Maximum pressure / Maximální tlak / Pressione	15 bar
Temperature / Teplota / Temperatura	-10° C / +50° C
Regulation range / Regulační rozsah / Campo di regolazione	0-2bar 0-4bar 0-8bar standard 0-12bar
6 bar flow rate with Δp 1bar / Průtok 6 barů s Δp 1bar / Portata a 6 bar con Δp 1bar	600NI/min
Manometer fastening / Upevnění manometrem / Attacco manometro	1/8

ORDERING CODE / OBJEDNÁVKOVÝ KÓD / CHIAVE DI CODIFICA

X M 0 0 0 0

- Regulation range / Regulační rozsah / Campo di regolazione
1=0-2bar
2=0-4bar
3=0-8bar STANDARD
4=0-12bar
- Thread / Závit / Filetto
1=G 1/8
2=G 1/4

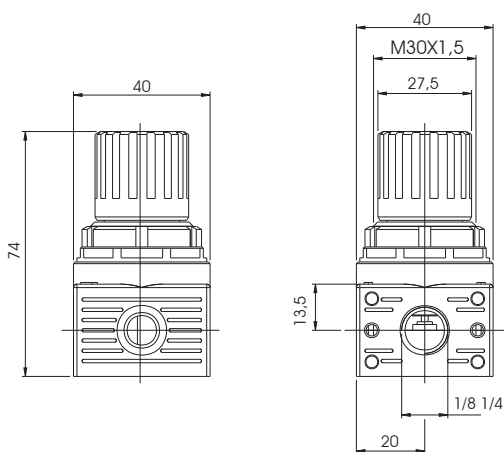

COMPONENTS / KOMPONENTY / COMPONENTI

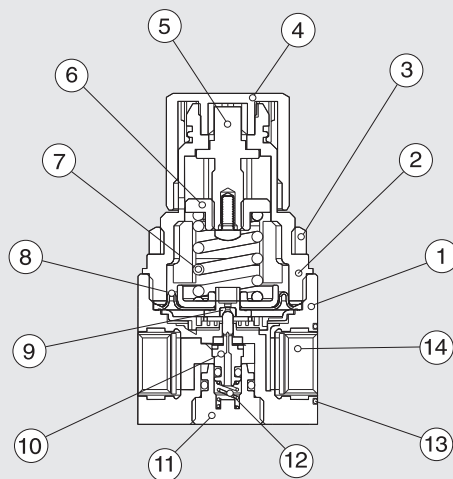

1	Body / Tělo / Corpo	polymer / polymer / polimero
2	bell / zvon / campana	polymer / polymer / polimero
3	fixing nut / upevňovací matice / ghiera di fissaggio	polymer / polymer / polimero
4	knob / knoflík / manopola	polymer / polymer / polimero
5	register screw / stavěcí šroub / vite di registro	brass / bress / ottone
6	female screw / samice šroub / chiocciola	brass / bress / ottone
7	register spring / pružina / molla di registro	steel / acier / acciaio
8	membrána / membrána / membrana	
9	seal / Těsnění / guarnizione	NBR
10	shutter / závěrky / otturatore	NBR
11	plug / zástrčka / tappo	polymer / polymer / polimero
12	spring / pružina / molla	stainless steel / acier inox / acciaio inox
13	o-ring / O-kroužek	NBR
14	threaded insert / závit / inserto filettato	brass / bress / ottone



TECHNICAL DATA / TECHNICKÁ DATA / DATI TECNICI

Fluid / Tekutina / Fluido	Water / Voda / Acqua
Maximum pressure / Maximální tlak / Pressione	15 bar
Temperature / Teplota / Temperatura	-10° C / +50° C
Regulation range / Regulační rozsah / Campo di regolazione	0-2bar 0-4bar 0-8bar standard 0-12bar
Manometer fastening / Upevnění manometrem / Attacco manometro	1/8

ORDERING CODE / OBJEDNÁVKOVÝ KÓD / CHIAVE DI CODIFICA

X Q 0 0 0 0

- Regulation range / Regulační rozsah / Campo di regolazione
1=0-2bar
2=0-4bar
3=0-8bar STANDARD
4=0-12bar
- Thread / Závít / Filetto
1= G 1/8
2= G 1/4

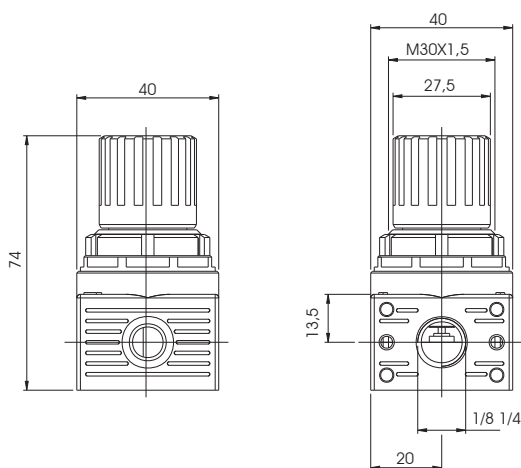

COMPONENTS / KOMPONENTY / COMPONENTI

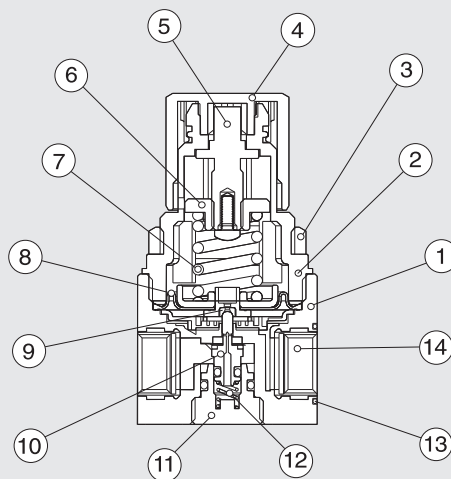

- | | | |
|----|--|---|
| 1 | Body / Tělo / Corpo | polymer / polymer / polimero |
| 2 | bell / zvon / campana | polymer / polymer / polimero |
| 3 | fixing nut / upevňovací matice / ghiera di fissaggio | polymer / polymer / polimero |
| 4 | knob / knoflík / manopola | polymer / polymer / polimero |
| 5 | register screw / stavěcí šroub / vite di registro | brass / bress / ottone |
| 6 | female screw / samice šroub / chiocciola | brass / bress / ottone |
| 7 | spring / pružina / molla | steel / acier / acciaio |
| 8 | membrána / membrána / membrana | |
| 9 | seal / Těsnění / guarnizione | NBR |
| 10 | shutter / závěrky / otturatore | NBR |
| 11 | plug / zástrčka / tappo | polymer / polymer / polimero |
| 12 | spring / pružina / molla | stainless steel / acier inox / acciaio inox |
| 13 | o-ring / O-kroužek | NBR |
| 14 | threaded insert / závít / inserto filettato | brass / bress / ottone |



TECHNICAL DATA / TECHNICKÁ DATA / DATI TECNICI

Fluid / Tekutina / Fluido	Air / Vzduch / Aria
Maximum pressure / Maximální tlak / Pressione	15 bar
Temperature / Teplota / Temperatura	-10° C / +50° C
Regulation range / Regulační rozsah / Campo di regolazione	0-2bar 0-4bar 0-8bar standard 0-12bar
Filtration grade / Filtrační schopnost / Grado di filtrazione	5µm - 20µm standard - 50µm
6 bar flow rate with Δp 1bar / Průtok 6 barů s Δp 1bar / Portata a 6 bar con Δp 1bar	600NI/min
Manometer fastening / Upevnění manometrem / Attacco manometro	1/8
Bowl capacity / Kapacita nádoby / Capacità tazza	17,5cm ³

ORDERING CODE / OBJEDNÁVKOVÝ KÓD / CHIAVE DI CODIFICA

X P 0 0 0 0 1

Filtration grade Filtrační schopnost Grado di filtrazione 1= 5 µm 2= 20 µm STANDARD 3= 50 µm	Regulation range / Regulační rozsah / Campo di regolazione 1=0-2bar 2=0-4bar 3=0-8bar STANDARD 4=0-12bar
Thread / Závít / Filetto 1=G 1/8 2=G 1/4	

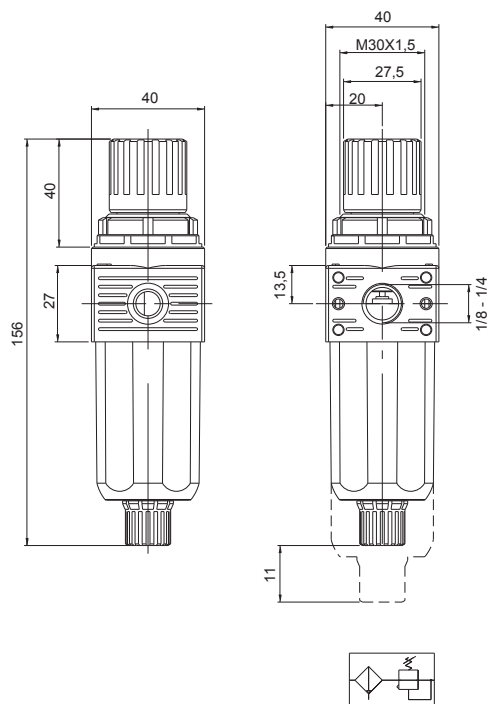

COMPONENTS / KOMPONENTY / COMPONENTI

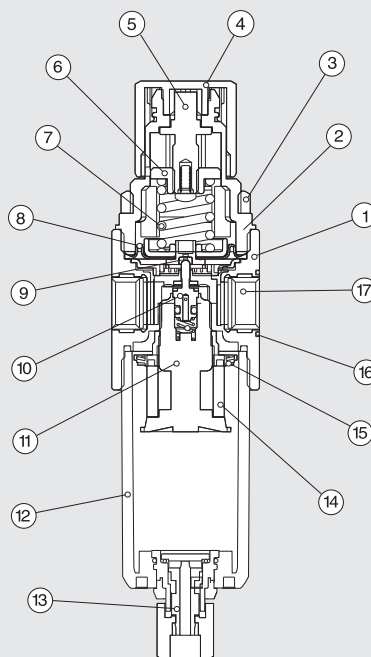

1	Body / Tělo / Corpo	polymer / polymer / polimero
2	bell / zvon / campana	polymer / polymer / polimero
3	fixing nut / upevňovací matice / ghiera	polymer / polymer / polimero
4	knob / knoflík / manopola	polymer / polymer / polimero
5	register screw / stavěcí šroub / vite di registro	brass / bress / ottone
6	female screw / samice šroub / chiocciola	brass / bress / ottone
7	register spring / pružina / molla di registro	steel / acier / acciaio
8	membrána / membrána / membrana	
9	seal / Těsnění / guarnizione	NBR
10	shutter / závěrky / otturatore	NBR
11	filter ring / filtrační kroužek / portafiltro	polymer / polymer / polimero
12	bowl / nádoba / tazza	polymer / polymer / polimero
13	cond. exhaust / Odvod koncentráту. / scarico cond.	polymer / polymer / polimero
14	cartridge / kazeta / cartuccia	PE
15	slinger / upevňovací matice / centrifugatore	polymer / polymer / polimero
16	o-ring / O-kroužek / o-ring	NBR
17	threaded insert / insert závít / inserto filettato	brass / bress / ottone



TECHNICAL DATA / TECHNICKÁ DATA / DATI TECNICI

Fluid / Tekutina / Fluido	Air / Vzduch / Aria
Maximum pressure / Maximální tlak / Pressione	15 bar
Temperature / Teplota / Temperatura	-10° C / +50° C
6 bar flow rate with Δp 1bar / Průtok 6 barů s Δp 1bar / Portata a 6 bar con Δp 1bar	700NI/min
Bowl capacity / Kapacita nádoby / Capacità tazza	28 cm ³

STANDARD PRODUCTS / STANDARDNÍ VÝROBKY / PRODOTTI STANDARD

Code Kód Codice	Size Velikost Taglia	Thread Závit Filetto	Flow rate Průtok Portata
XL0110	0	1/8	700NI/min
XL0210	0	1/4	700NI/min

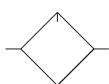
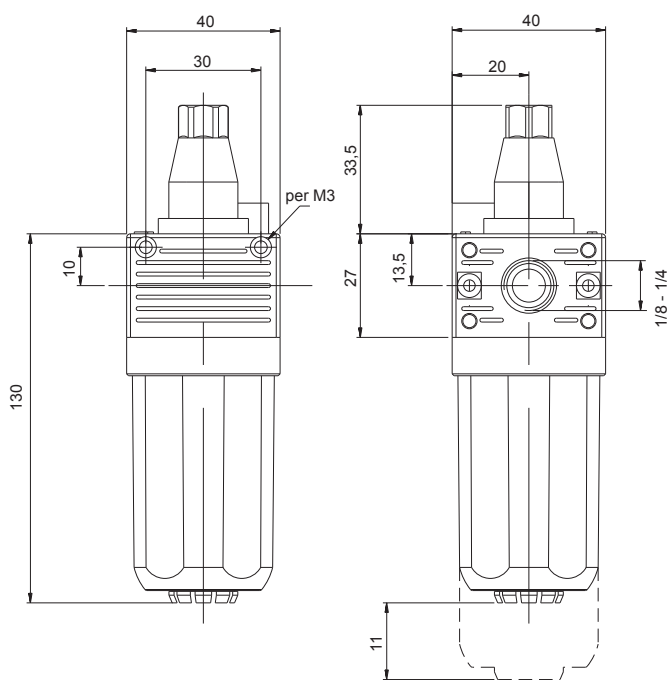

COMPONENTS / KOMPONENTY / COMPONENTI

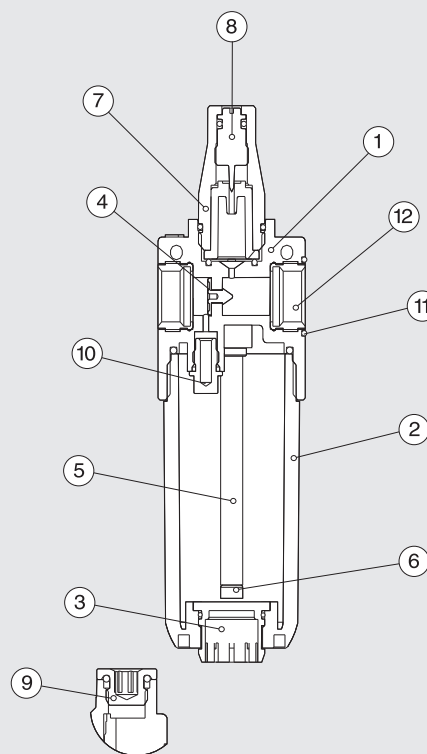

1 Body / Tělo / Corpo	polymer / polymer / polimero
3 bowl / nádoby / tazza	polymer / polymer / polimero
3 plug / zástrčka / tappo	polymer / polymer / polimero
4 membrána / membrána / membrana	polymer / polymer / polimero
5 tube / tube / tubo	Pa11
6 small filter / filtrační kroužek / filtrino	bronze / bronze / bronzo
7 kupole / hledítko / cupola	polymer / polymer / polimero
8 pin / stavěcí šroub / spillo	brass / bress / ottone
9 plug / zástrčka / tappo	brass / bress / ottone
10 air diffuser / diffuseur / diffusore	brass / bress / ottone
11 o-ring / O-kroužek / o-ring	NBR



TECHNICAL DATA / TECHNICKÁ DATA / DATI TECNICI

Fluid / Tekutina / Fluido	Air / Vzduch / Aria
Maximum pressure / Maximální tlak / Pressione	15 bar
Temperature / Teplota / Temperatura	-10° C / +50° C
Regulation range / Regulační rozsah / Campo di regolazione	0-2bar 0-4bar 0-8bar standard 0-12bar
Filtration grade / Filtrační schopnost / Grado di filtrazione	5µm - 20µm standard - 50µm
6 bar flow rate with Δp 1bar / Průtok 6 barů s Δp 1bar / Portata a 6 bar con Δp 1bar	260 NI/min
Manometer fastening / Upevnění manometrem / Attacco manometro	1/8 1/4

ORDERING CODE / OBJEDNÁVKOVÝ KÓD / CHIAVE DI CODIFICA

X S 0 0 0 1

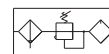
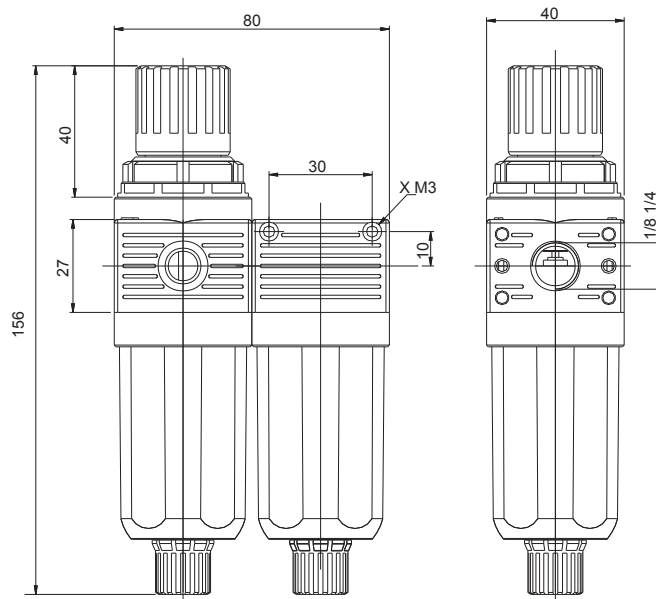
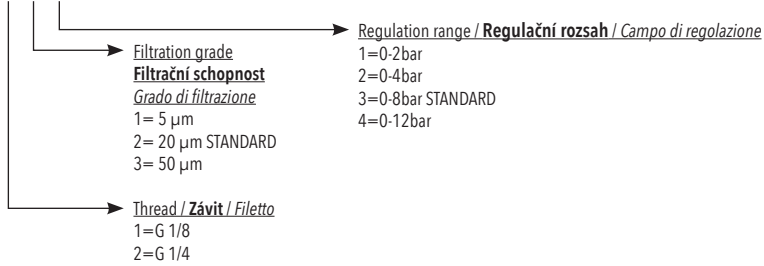



TECHNICAL DATA / TECHNICKÁ DATA / DATI TECNICI

Fluid / Tekutina / Fluido	Air / Vzduch / Aria
Maximum pressure / Maximální tlak / Pressione	15 bar
Temperature / Teplota / Temperatura	-10° C / +50° C
Regulation range / Regulační rozsah / Campo di regolazione	0-2bar 0-4bar 0-8bar standard 0-12bar
Filtration grade / Filtrační schopnost / Grado di filtrazione	5µm - 20µm standard - 50µm
6 bar flow rate with Δp 1bar / Průtok 6 barů s Δp 1bar / Portata a 6 bar con Δp 1bar	280 NI/min
Manometer fastening / Upevnění manometrem / Attacco manometro	1/8
Bowl capacity / Kapacita nádobky / Capacità tazza	17,5cm ³

ORDERING CODE / OBJEDNÁVKOVÝ KÓD / CHIAVE DI CODIFICA

X T 0 0 0 1 1

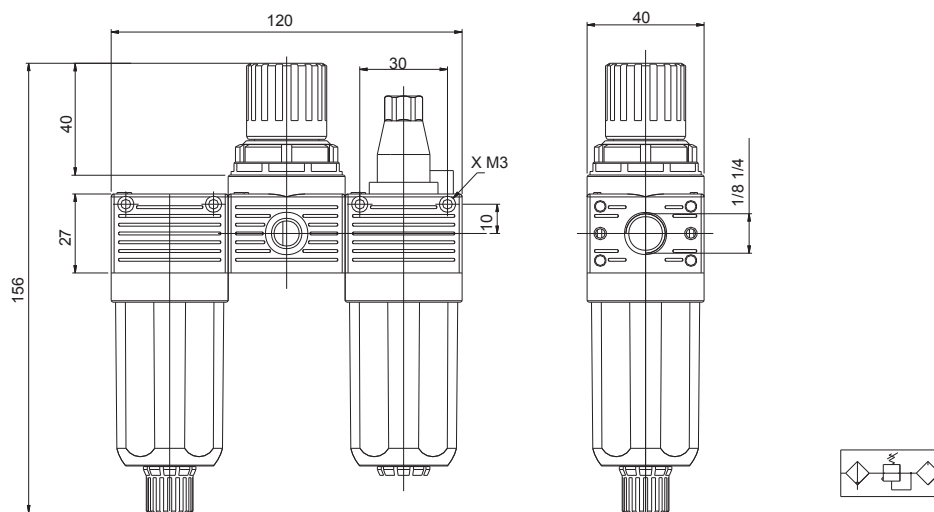
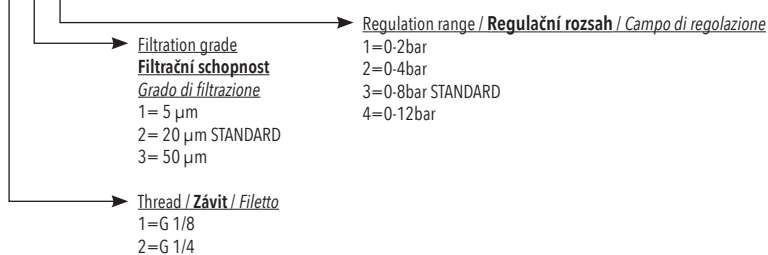



TECHNICAL DATA / TECHNICKÁ DATA / DATI TECNICI

Fluid / Tekutina / Fluido	Air / Vzduch / Aria
Maximum pressure / Maximální tlak / Pressione Max	15 bar
Temperature / Teplota / Temperatura	-10° C / +50° C
Filtration grade / Filtrační schopnost / Grado di filtrazione	5µm + 0,01 0µm
6 bar flow rate with Δp 1bar / Průtok 6 barů s Δp 1bar / Portata a 6 bar con Δp 1bar	370 NI/min
Bowl capacity / Kapacita nádoby / Capacità tazza	17,5cm ³

STANDARD PRODUCTS / STANDARDNÍ VÝROBKY / PRODOTTI STANDARD

Code Kód Codice	Size Velikost Taglia	Thread Závit Filetto	Filtration filtrace Filtrazione	Flow rate Průtok Portata	Exhaust Odvod koncentráту Scarico
XD0101	0	1/8	5µm + 0.01µm	370NI/min	S/M
XD0201	0	1/4	5µm + 0.01µm	370NI/min	S/M

S/M: Semi-automatic / Manual / Poloautomatický / manuální / Semiautomatico / Manuale

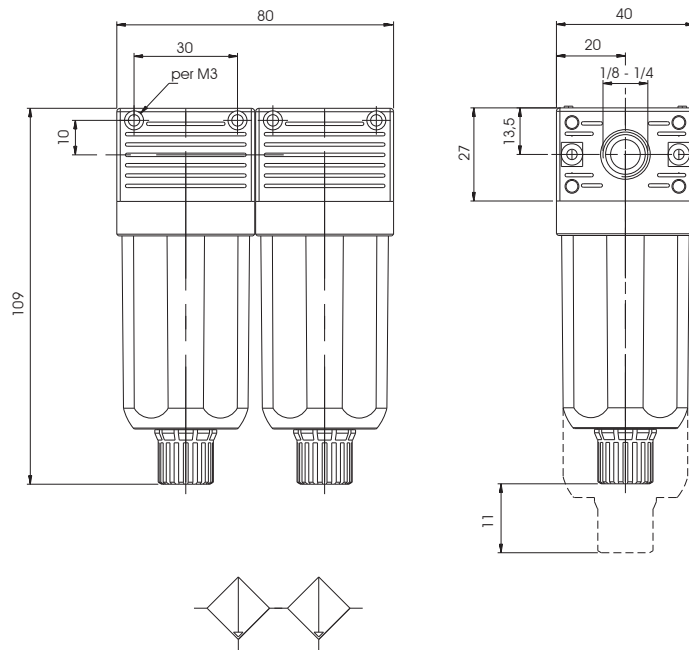

INFORMACES / INFORMACE / INFORMAZE

Coalescer cartridge is made of microfiber layer with external stainless steel structure. Coalescing cartridge uses inertial impact, interception and coalescence to gather liquid particles into drops. These drops will fall into bowl bottom.

Coalescing Filter is used as Oil Separator which removes oil-vapours from air output. We recommend to install a 5 µm Filter upstream to protect coalescing filter from choking of cartridge.

Koalescenční kazeta je vyrobena z mikrovlákna s vnější strukturou z nerezové oceli. Koalescenční kazeta využívá setrvačný náraz, zachycování a koalescence pro shromažďování kapalných částic do kapek. Tyto kapky padnou na dno mísy.
Koalescenční filtr se používá jako odlučovač oleje, který odstraňuje výpary z výstupu vzduchu. Doporučujeme nainstalovat před filtrační kroužek 5 µm filtr chrání koalescenční filtr před udušením kazety.

La cartuccia a coalescenza è costituita da uno strato di microfibre sorrette da una struttura esterna in acciaio inox.
 La cartuccia a coalescenza, sfruttando i principi dell'impatto inerziale, dell'intercettazione e della coalescenza, obbliga le particelle di liquido che l'attraversano ad unirsi formando microgocce più grandi che, per gravità, precipitano sul fondo del contenitore.
 Il filtro a coalescenza usato come disoleatore permette di ottenere un'aria in uscita priva di olio.
 Si consiglia di montare a monte del filtro a coalescenza un filtro da 5 µm che trattiene le particelle solide evitando così l'intasamento della cartuccia a coalescenza.

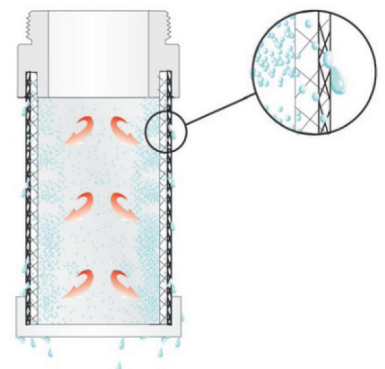



TECHNICAL DATA / TECHNICKÁ DATA / DATI TECNICI

Fluid / Tekutina / <i>Fluido</i>	Air / Vzduch / <i>Aria</i>		
Maximum pressure / Maximální tlak / <i>Pressione Max</i>	15 bar		
Temperature / Teplota / <i>Temperatura</i>	-10° C / +50° C		
Filtration grade / Filtrační schopnost / <i>Grado di filtrazione</i>	5 - 20 - 50 µm		
6 bar flow rate with Δp 1bar / Průtok 6 barů s Δp 1bar / <i>Portata a 6 bar con Δp 1bar</i>	1=1900 NI/min	2=3750NI/min	3=6250NI/min
Bowl capacity / Kapacita nádobky / <i>Capacità tazza</i>	1=22cm ³	2=46cm ³	3=89,5cm ³
Wall clamping screws / Upínací šrouby na zeď / <i>Viti per fissaggio</i>	1=M4X14	2=M5X18	3=M6X20

STANDARD PRODUCTS / STANDARDNÍ VÝROBKY / PRODOTTI STANDARD

Code Kód Codice	Size Velikost Taglia	Thread Závit Filetto	Filtration filtrace Filtrazione	Flow rate Průtok Portata	Exhaust Odvod koncentráту Scarico
XF1221	1	1/4	20µm	1900NI/min	S/M
XF1321	1	3/8	20µm	1900NI/min	S/M
XF2321	2	3/8	20µm	3750NI/min	S/M
XF2421	2	1/2	20µm	3750NI/min	S/M
XF2422	2	1/2	20µm	3750NI/min	A
XF3521	3	3/4	20µm	6250NI/min	S/M
XF3621	3	1"	20µm	6250NI/min	S/M
XF3622	3	1"	20µm	6250NI/min	A

S/M: Semi-automatic / Manual / **Poloautomatický / manuální / Semiautomatico / Manuale**
A: Automatic / **Automatický / Automatico**

ORDERING CODE / OBJEDNÁVKOVÝ KÓD / CHIAVE DI CODIFICA

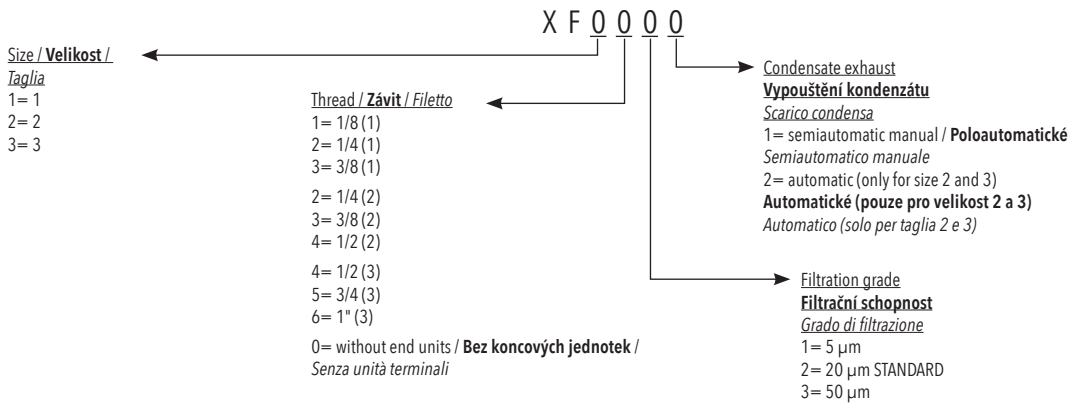

FLOW CHARACTERISTICS / CHARAKTERISTIKY TOKU / CARATTERISTICHE DI FLUSSO

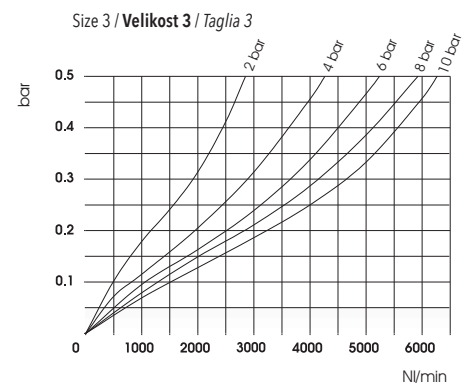
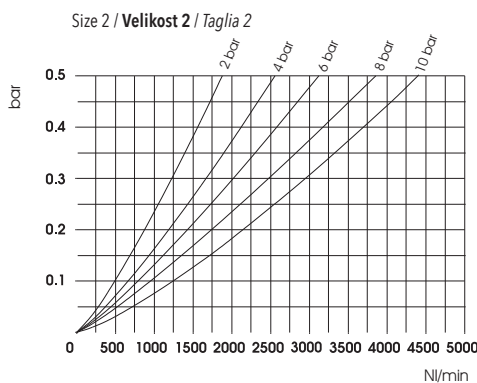
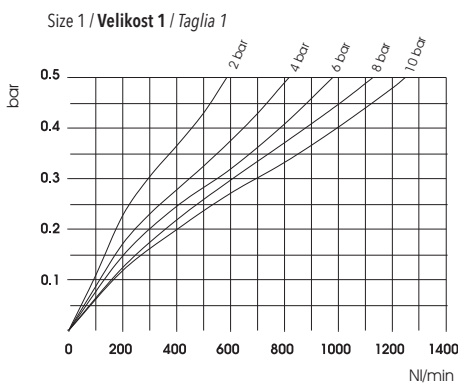

COMPONENTS / **KOMPONENTY** / COMPONENTI

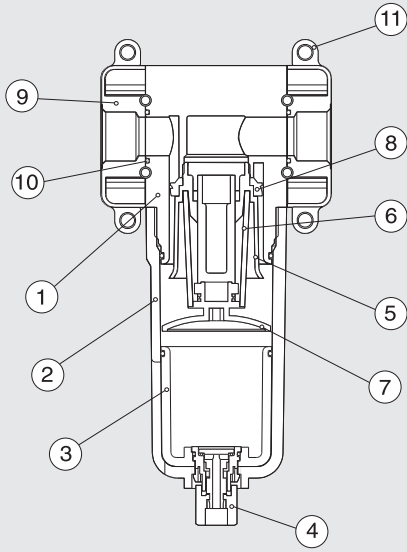

1	Body / Tělo / Corpo	polymer / polymer / polimero
2	bowl / nádobka / tazza	polymer / polymer / polimero
3	glass / sklenka / bicchiere	polymer / polymer / polimero
4	condensate exhaust / Vypouštění kondenzátu	polymer / polymer / polimero
5	filter ring / těsnění pro filtrační kroužek / portafiltro	polymer / polymer / polimero
6	filtering cartridge / filtrační kazeta / cartuccia filtrante	sintered bronze / bronzo sinterizzato
7	deflector / deflecteur / deflettore	polymer / polymer / polimero
8	slinger / upevňovací matice / centrifugatore	polymer / polymer / polimero
9	end part / terminál / terminale	zama
10	o-ring / O-kroužek	NBR
11	fixing element / element fixation / elemento fissaggio	zama

DIMENSIONS / ROZMĚRY / DIMENSIONI

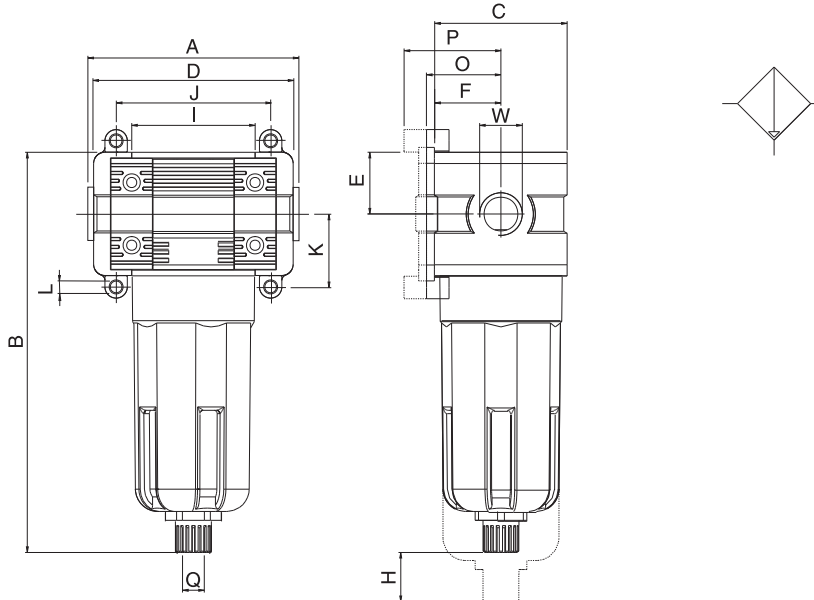

	A	B	C	D	W	E	F	H	I	J	K	L	O	P	Q
Size 1	75,5	146	45	72	1/8 - 1/4 - 3/8	21	22,5	39	43	54	26	M4	26	32,5	1/8
Size 2	89	178,5	59	89	1/4 - 3/8 - 1/2	27,5	28,5	48	55	69	32,5	M5	32	38,5	1/8
Size 3	106	197,5	70	100	1/2 - 3/4 - 1	32,5	35	50	65	79	38	M6	38,5	45	1/8



TECHNICAL DATA / TECHNICKÁ DATA / DATI TECNICI

Fluid / Tekutina / Fluido	5µm filtrační kroužek air / 5µm filtrovaného vzduchu / Aria filtrata a 5µm
Maximum pressure / Maximální tlak / Pressione Max	15 bar
Temperature / Teplota / Temperatura	-10° C / +50° C
Filtration grade / Filtrační schopnost / Grado di filtrazione	0.01µm
6 bar flow rate with Δp 1 bar / Průtok 6 barů s Δp 1bar / Portata a 6 bar con Δp 1 bar	1=700 NI/min 2=725 NI/min 3=920 NI/min
Bowl capacity / Kapacita nádobky / Capacità tazza	1=22cm ³ 2=46cm ³ 3=89,5cm ³
Wall clamping screws / Upínací šrouby na zeď / Viti per fissaggio	1=M4X14 2=M5X18 3=M6X20

STANDARD PRODUCTS / PRODUIT STANDARD / PRODOTTI STANDARD

Code Kód Codice	Size Velikost Taglia	Thread Závit Filetto	Filtration filtrace Filtrazione	Flow rate Průtok Portata	Exhaust Odvod koncentráту Scarico
XC1201	1	1/4	0.01µm	700NI/min	S/M
XC1301	1	3/8	0.01µm	700NI/min	S/M
XC2301	2	3/8	0.01µm	725NI/min	S/M
XC2401	2	1/2	0.01µm	725NI/min	S/M
XC3501	3	3/4	0.01µm	920NI/min	S/M
XC3601	3	1"	0.01µm	920NI/min	S/M

S/M: Semi-automatic / Manual / Poloautomatický / manuální / Semiautomatico / Manuale

DIMENSIONS / ROZMĚRY / DIMENSIONI

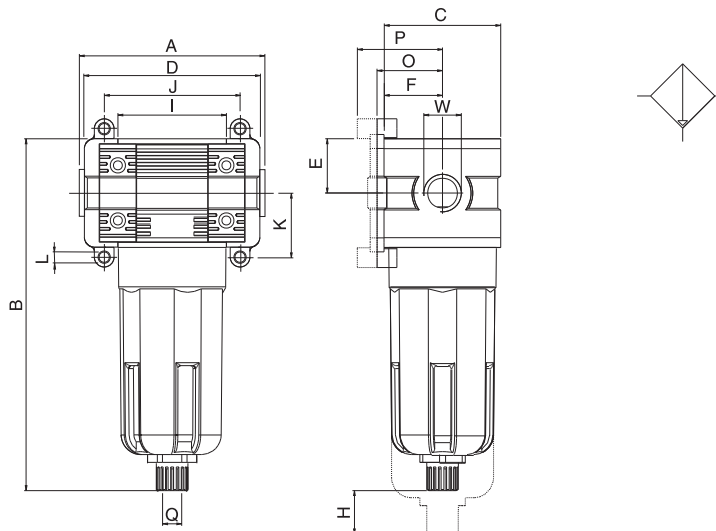

	A	B	C	D	W	E	F	H	I	J	K	L	O	P	Q
Size 1	75,5	146	45	72	1/8 - 1/4 - 3/8	21	22,5	39	43	54	26	M4	26	32,5	1/8
Size 2	89	178,5	59	89	1/4 - 3/8 - 1/2	27,5	28,5	48	55	69	32	M5	32	38,5	1/8
Size 3	106	197,5	70	100	1/2 - 3/4 - 1	32,5	35	50	65	79	38,5	M6	38,5	45	1/8

INFORMACES / INFORMACE / INFORMAZE

Coalescer cartridge is made of microfiber layer with external stainless steel structure. Coalescing cartridge uses inertial impact, interception and coalescence to gather liquid particles into drops. These drops will fall into bowl bottom. Coalescing Filter is used as Oil Separator which removes oil-vapours from air output. We recommend to install a 5 µm Filter upstream to protect coalescing filter from choking of cartridge.

Koalescenční kazeta je vyrobena z mikrovlákna s vnější strukturou z nerezové oceli. Koalescenční kazeta využívá setrvačný náraz, zachycování a koalescence pro shromažďování kapalných částic do kapek. Tyto kapky padnou na dno mísy. Koalescenční filtr se používá jako odlučovač oleje, který odstraňuje výparu z výstupu vzduchu. Doporučujeme nainstalovat před filtrační kroužek 5 µm filtr chrání koalescenční filtr před udušením kazety.

La cartuccia a coalescenza è costituita da uno strato di microfibre sorrette da una struttura esterna in acciaio inox.

La cartuccia a coalescenza, sfruttando i principi dell'impatto inerziale, dell'intercettazione e della coalescenza, obbliga le particelle di liquido che l'attraversano ad unirsi formando microgocce più grandi che, per gravità, precipitano sul fondo del contenitore.

Il filtro a coalescenza usato come disoleatore permette di ottenere un'aria in uscita priva di olio.

Si consiglia di montare a monte del filtro a coalescenza un filtro da 5 µm che trattienga le particelle solide evitando così l'intasamento della cartuccia a coalescenza.

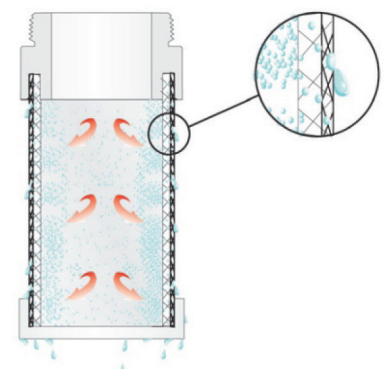



TECHNICAL DATA / TECHNICKÁ DATA / DATI TECNICI

Fluid / Tekutina / Fluido	Air / Vzduch / Aria
Maximum pressure / Maximální tlak / Pressione Max	15 bar
Temperature / Teplota / Temperatura	-10° C / +50° C
Regulation range / Regulační rozsah / Campo di regolazione	0-2bar 0-4bar 0-8bar standard 0-12bar
6 bar flow rate with Δp 1bar / Průtok 6 barů s Δp 1bar / Portata a 6 bar con Δp 1bar	1=2050NI/min 2=3200NI/min 3=6200NI/min
Manometer fastening / Upevnění manometrem / Attacco manometro	1/8

STANDARD PRODUCTS / STANDARDNÍ VÝROBKY / PRODOTTI STANDARD

Code Kód Codice	Size Velikost Taglia	Thread Závit Filetto	Regulation Průtok Regolazione	Flow rate Regulation Portata
XR1230	1	1/4	0-8bar	2050NI/min
XR1330	1	3/8	0-8bar	2050NI/min
XR2330	2	3/8	0-8bar	3200NI/min
XR2430	2	1/2	0-8bar	3200NI/min
XR3530	3	3/4	0-8bar	6200NI/min
XR3630	3	1"	0-8bar	6200NI/min

ORDERING CODE / OBJEDNÁVKOVÝ KÓD / CHIAVE DI CODIFICA

X R 0 0 0 0

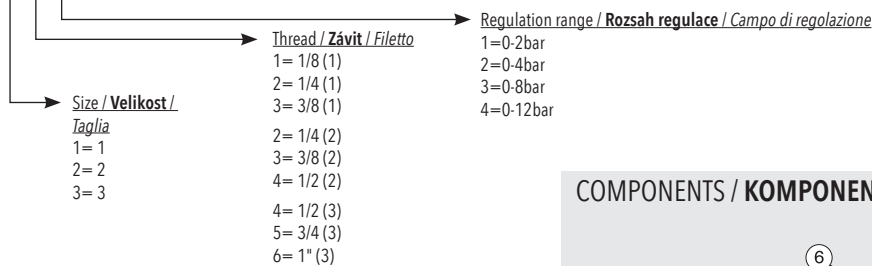

DIMENSIONS / ROZMĚRY / DIMENSIONI

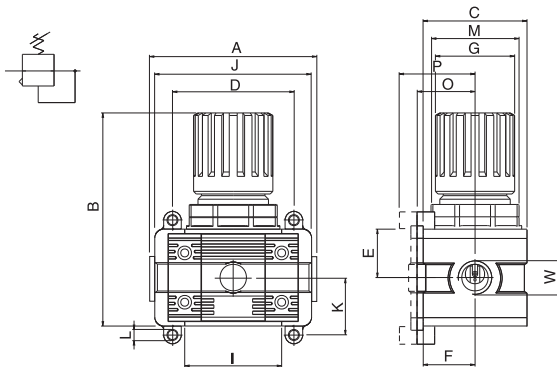

	1	2	3
A	75,5	89	106
B	97	121	140,5
C	45	59	70
D	72	89	100
W	1/8-1/4-3/8	1/4-3/8-1/2	1/2-3/4-1"
E	21	27,5	32,5
F	22,5	28,5	35
G	36	45	50,5
I	43	55	65
J	54	69	79
K	26	32,5	38
L	Ø X M4	Ø X M5	Ø X M6
O	26	32	38,5
P	32,5	38,5	45
M	M32x1,5	M40x1,5	M47x1,5

COMPONENTS / KOMPONENTY / COMPONENTI

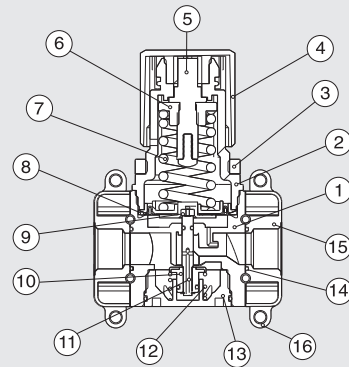

1	Body / Tělo / Corpo	polymer / polymer / polimero
2	bell / zvon / campana	polymer / polymer / polimero
3	fixing nut / upevňovací matice / ghiera di fissaggio	polymer / polymer / polimero
4	knob / knoflík / manopola	polymer / polymer / polimero
5	register screw / stavěcí šroub / vite di registro	brass / ottone
6	female screw / samice šroub / chiocciola	brass / ottone
7	register spring / pružina / molla di registro	steel / acciaio
8	membrána / membrána / membrana	
9	seal / Těsnění / guarnizione	NBR
10	shutter / závěrky / otturatore	NBR
11	rod / tyč / asta	brass / ottone
12	spring / pružina / molla	stainless steel / acciaio inox
13	plug / zástrčka / tappo	polymer / polymer / polimero
14	o-ring / O-kroužek	NBR
15	end part / terminál / terminale	zama / zama
16	fixing element / upevňovací otvor / elemento di fissaggio	zama / zama



TECHNICAL DATA / TECHNICKÁ DATA / DATI TECNICI

Fluid / Tekutina / Fluido	Air / Vzduch / Aria
Maximum pressure / Maximální tlak / Pressione Max	15 bar
Temperature / Teplota / Temperatura	-10° C / +50° C
Regulation range / Regulační rozsah / Campo di regolazione	5 - 20 - 50µm
6 bar flow rate with Δp 1bar / Průtok 6 barů s Δp 1bar / Portata a 6 bar con Δp 1bar	1=1650 NI/min 2=300NI/min 3=4500NI/min
Bowl capacity / Kapacita nádobky / Capacità tazza	1=22cm ³ 2=46cm ³ 3=89,5cm ³
Regulation range / Regulační rozsah / Campo di regolazione	0-2bar 0-4bar 0-8bar standard 0-12bar
Wall clamping screws / Upínací šrouby na zeď / Viti per fissaggio	1=M4X14 2=M5X18 3=M6X20

STANDARD PRODUCTS / STANDARDNÍ VÝROBKY / PRODOTTI STANDARD

Code Kód Codice	Size Velikost Taglia	Thread Závit Filetto	Filtration filtrace Filtrazione	Flow rate Průtok Portata	Regulation Régulation Regolazione	Exhaust Odvod koncentrátu Scarico
XP12231	1	1/4	20µm	1650NI/min	0 - 8bar	S/M
XP13231	1	3/8	20µm	1650NI/min	0 - 8bar	S/M
XP23231	2	3/8	20µm	3000NI/min	0 - 8bar	S/M
XP24231	2	1/2	20µm	3000NI/min	0 - 8bar	S/M
XP24232	2	1/2	20µm	3000NI/min	0 - 8bar	A
XP35231	3	3/4	20µm	4500NI/min	0 - 8bar	S/M
XP36231	3	1"	20µm	4500NI/min	0 - 8bar	S/M
XP36232	3	1"	20µm	4500NI/min	0 - 8bar	A

S/M: Semi-automatic / Manual / **Poloautomatický / manuální / Semiautomatico / Manuale**
A: Automatic / **Automatický / Automatico**

ORDERING CODE / OBJEDNÁVKOVÝ KÓD / CHIAVE DI CODIFICA

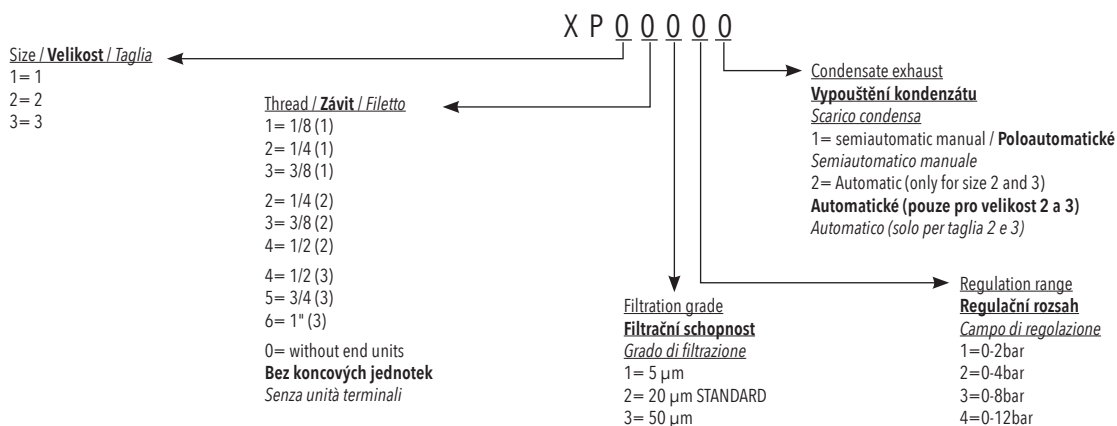

FLOW CHARACTERISTICS / CHARAKTERISTIKY TOKU / CARATTERISTICHE DI FLUSSO

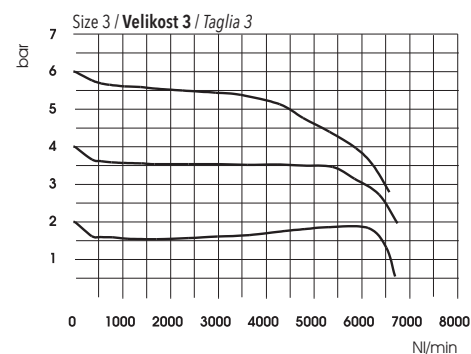
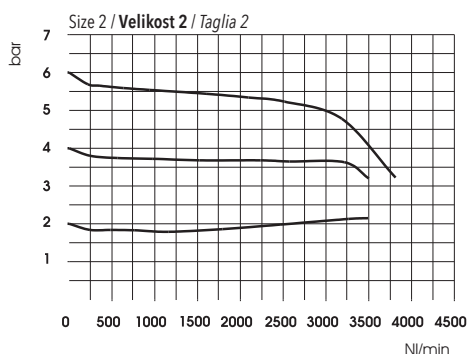
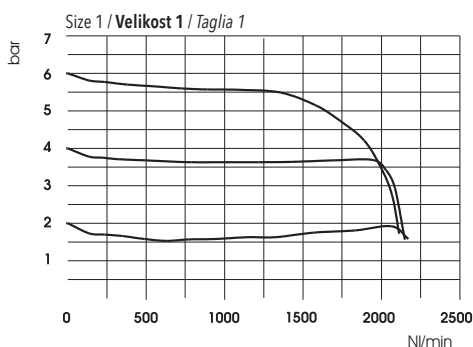

COMPONENTS / **KOMPONENTY** / COMPONENTI

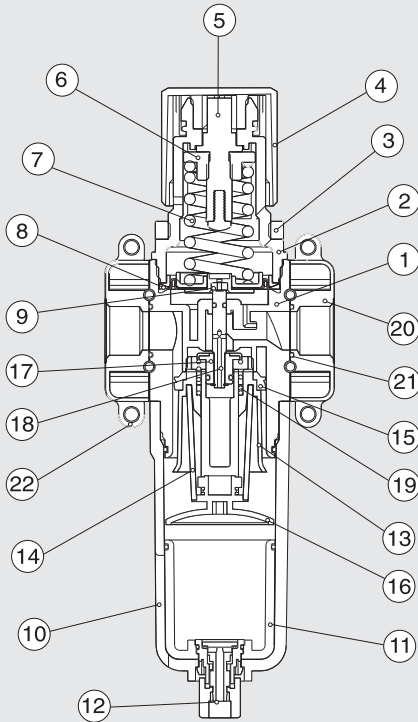

1	Body / Tělo / <i>Corpo</i>	polymer / polymer / <i>polimero</i>
2	bell / zvon / <i>campana</i>	polymer / polymer / <i>polimero</i>
3	fixing nut / upevňovací prstenová matice / <i>ghiera di fissaggio</i>	polymer / polymer / <i>polimero</i>
4	knob / knoflík / <i>manopola</i>	polymer / polymer / <i>polimero</i>
5	register screw / stavěcí šroub / <i>vite di registro</i>	brass / bress / <i>ottone</i>
6	female screw / samice šroub / <i>chiocciola</i>	brass / bress / <i>ottone</i>
7	register spring / pružina / <i>molla di registro</i>	steel / acier / <i>acciaio</i>
8	membrána / membrána / <i>membrana</i>	
9	seal / těsnění / <i>guarnizione</i>	NBR
10	bowl / nádobka / <i>tazza</i>	polymer / polymer / <i>polimero</i>
11	glass / sklenka / <i>bicchiere</i>	polymer / polymer / <i>polimero</i>
12	condensate exhaust / Vypouštění kondenzátu / <i>scarico condensa</i>	polymer / polymer / <i>polimero</i>
13	filter ring / těsnění filtrační kroužek / <i>portafiltro</i>	polymer / polymer / <i>polimero</i>
14	filtering cartridge / filtrační kazeta / <i>cartuccia filtrante</i>	sintered bronze / bronze / <i>bronzo sinterizzato</i>
15	slinger / odstřikovací kroužek / <i>centrifugatore</i>	polymer / polymer / <i>polimero</i>
16	deflector / deflecteur / <i>deflettore</i>	polymer / polymer / <i>polimero</i>
17	shutter / zavěrky / <i>otturatore</i>	NBR
18	rod / tyč / <i>asta</i>	brass / bress / <i>ottone</i>
19	spring / pružina / <i>molla</i>	stainless steel / acier inox / <i>acciaio inox</i>
20	end part / terminál / <i>terminale</i>	zama / zamak / <i>zama</i>
21	o-ring / O-kroužek	NBR
22	fixing element / upevňovací prvek / <i>elemento di fissaggio</i>	zama / zamak / <i>zama</i>

DIMENSIONS / **ROZMĚRY** / *DIMENSIONI*

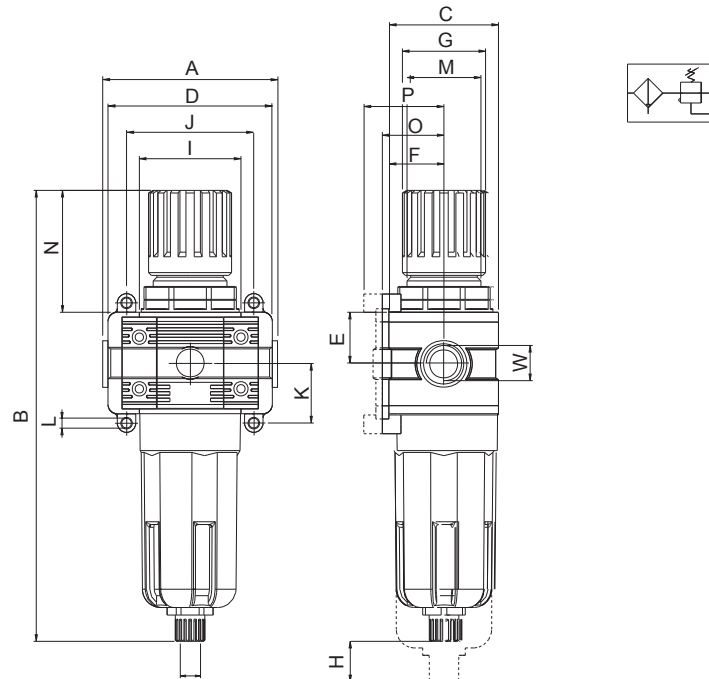

	A	B	C	D	W	E	F	G	H	I	J	K	L	M	N	O	P	Q
Size 1	75,5	198	45	72	1/8-1/4-3/8	21	22,5	36	39	43	54	26	M4	M32	52	26	32,5	1/8
Size 2	89	244,5	59	89	1/4-3/8-1/2	27,5	28,5	45	48	55	69	32,5	M5	M40	66	32	38,5	1/8
Size 3	106	273	70	100	1/2-3/4-1	32,5	35	50,5	50	65	79	38	M6	M47	75,5	38,5	45	1/8



TECHNICAL DATA / TECHNICKÁ DATA / DATI TECNICI

Fluid / Tekutina / Fluido	Air / Vzduch / Aria		
Maximum pressure / Maximální tlak / Pressione Max	15 bar		
Temperature / Teplota / Temperatura	-10° C / +50° C		
Filtration grade / Filtrační schopnost / Grado di filtrazione	5 - 20 - 50µm		
6 bar flow rate with Δp 1bar / Průtok 6 barů s Δp 1bar / Portata a 6 bar con Δp 1bar	1=2600 NI/min	2=5600NI/min	3=8200NI/min
Bowl capacity / Kapacita nádobky / Capacità tazza	1=22cm ³	2=46cm ³	3=89,5cm ³
Wall clamping screws / Upínací šrouby na zeď / Viti per fissaggio	1=M4X14	2=M5X18	3=M6X20
Recommended oil / Olejová mlha / Olio consigliato	Classe ISO 22 a Norma ISO 3448		

STANDARD PRODUCTS / STANDARDNÍ VÝROBKY / PRODOTTI STANDARD

Code Kód Codice	Size Velikost Taglia	Thread Závit Filetto	Flow rate Průtok Portata	Oil load Zatížení olejem Carico olio
XL1210	1	1/4	2600NI/min	M
XL1310	1	3/8	2600NI/min	M
XL1320	1	3/8	2600NI/min	A
XL2310	2	3/8	5600NI/min	M
XL2410	2	1/2	5600NI/min	M
XL2420	2	1/2	5600NI/min	A
XL3510	3	3/4	8200NI/min	M
XL3610	3	1"	8200NI/min	M
XL3620	3	1"	8200NI/min	A
XL3630	3	1"	8200NI/min	M2L

M: Manual / **Manuál** / Manuale
 A: Automatic to vacuum-operated
Automatické vakuum / Automatico a depressione
 M2L: Two steps sensor manual / **Manuál s dvouúrovňovým snímačem** / Manuale con sensore a due livelli

ORDERING CODE / OBJEDNÁVKOVÝ KÓD / CHIAVE DI CODIFICA

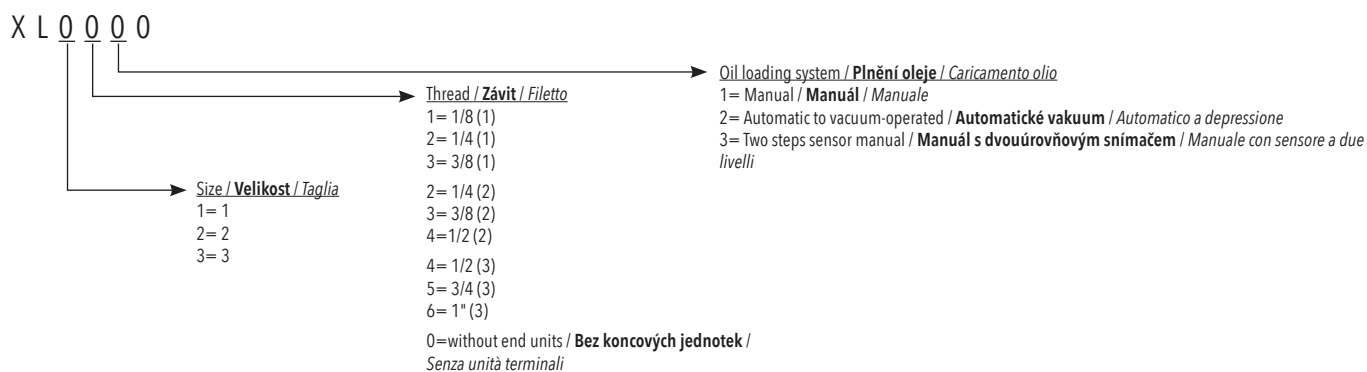

FLOW CHARACTERISTICS / CHARAKTERISTIKY TOKU / CARATTERISTICHE DI FLUSSO

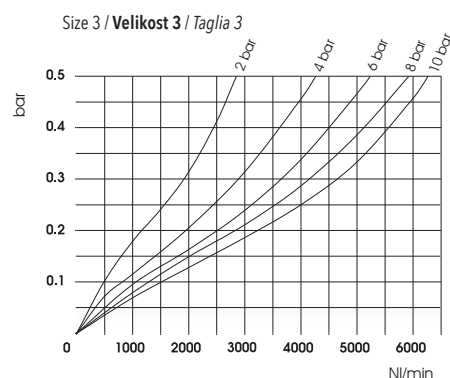
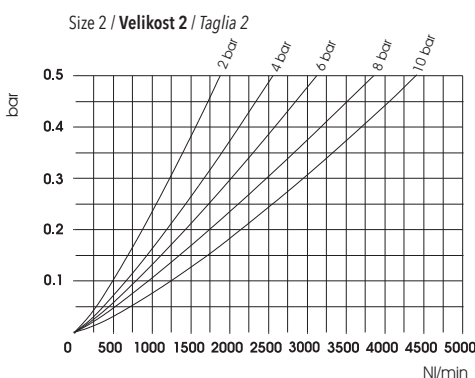
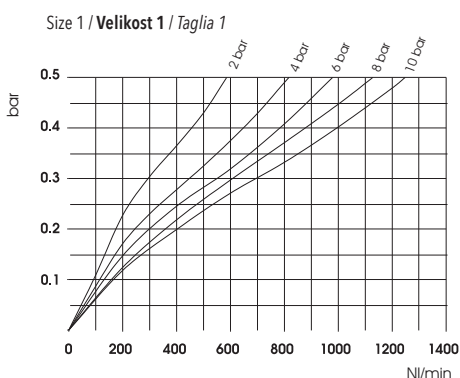

COMPONENTS / KOMPONENTY / COMPONENTI

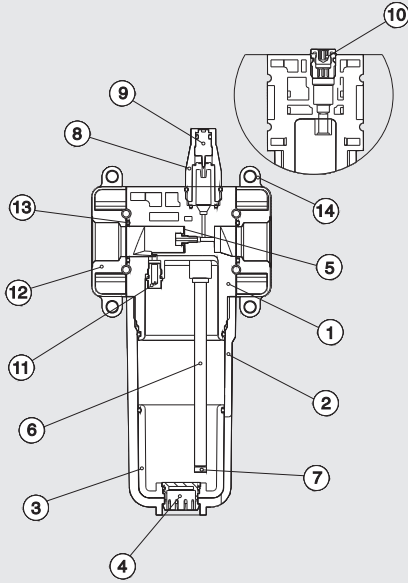

1	Body / Tělo / Corpo	polymer / polymer / polimero
2	bowl / nádobka / tazza	polymer / polymer / polimero
3	glass / sklenka / bicchiere	polymer / polymer / polimero
4	plug / zástrčka / tappo	polymer / polymer / polimero
5	membrána / membrána / membrana	
6	tube / tube / tubo	Pa11
7	small filter / filtrační kroužek / filtrino	
8	cupola / kupole / kupole	polymer / polymer / polimero
9	pin / pin / spillo	brass / bress / ottone
10	plug / zástrčka / tappo	brass / bress / ottone
11	diffuser / diffuseur / diffusore	brass / bress / ottone
12	end part / terminál / terminale	zama / zamak / zama
13	o-ring / O-kroužek	NBR
14	fixing part / upevňovací prvek / elemento di fissaggio	zama / zamak / zama

DIMENSIONS / ROZMĚRY / DIMENSIONI

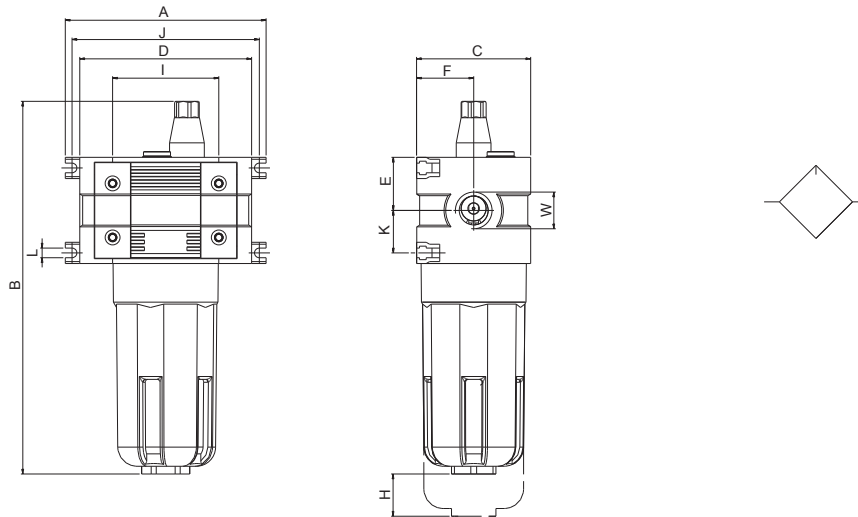

	A	B	C	D	W	E	F	H	I	J	K	L	M	O	P
Size 1	75,5	162	45	72	1/8-1/4-3/8	21	22,5	39	43	48,5	26	M4	29	26	32,5
Size 2	89	195	59	89	1/4-3/8-1/2	27,5	28,5	48	55	69	32,5	M5	29	32	38,5
Size 3	106	214	70	100	1/2-3/4-1	32,5	35	50	65	79	38	M6	29	38,5	45

ELECTRICAL DATA OIL LOADING SYSTEM TWO STEPS SENSOR MANUAL / PŘÍRUČKA SNÍMAČE ELEKTRICKÝCH ÚDAJŮ OLEJOVÝCH
OLEJŮ DVA KROKY / SCHEMI ELETRICI CARICAMENTO MANUALE OLIO A DUE LIVELLI

Cable length / **Délka kabelu** / Lunghezza cavo: 1500 mm

Current / **Proud** / Corrente: 0.5 A

Voltage / **Napětí** / Tensione: <24V

Capacity / **Kapacita** / Potenziale: 10W

minimum level
minimální úroveň
segnale al livello minimo

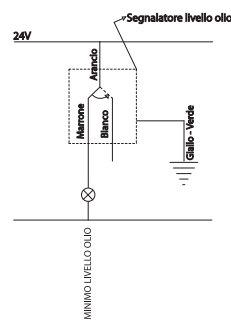

maximum level
maximální úroveň
segnale al livello massimo

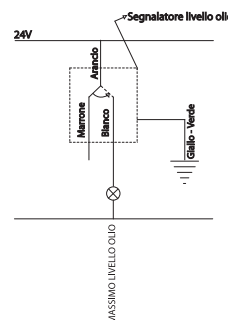

minimum and maximum level oil
signál hladiny oleje na minimum a maximum
segnale livello olio al minimo e al massimo

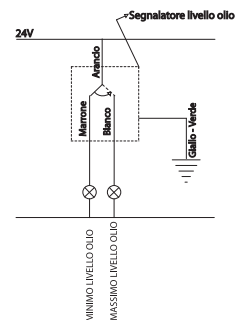



TECHNICAL DATA / TECHNICKÁ DATA / DATI TECNICI

Fluid / Tekutina / Fluido	Air / Vzduch / Aria
Maximum pressure / Maximální tlak / Pressione Max	15 bar
Temperature / Teplota / Temperatura	-10° C / +50° C
Filtration grade / Filtrační schopnost / Grado di filtrazione	5 - 20 - 50µm
6 bar flow rate with Δp 1bar / Průtok 6 barů s Δp 1bar / Portata a 6 bar con Δp 1bar	1=1100NI/min 2=2500NI/min 3=4300NI/min
Bowl capacity / Kapacita nádobky / Capacità tazza	1=22cm ³ 2=46cm ³ 3=89,5cm ³
Regulation range / Regulační rozsah / Campo di regolazione	0-2bar 0-4bar 0-8bar standard 0-12bar
Wall clamping screws / Upinací šrouby na zeď / Viti per fissaggio	1=M4X14 2=M5X18 3=M6X20

STANDARD PRODUCTS / STANDARDNÍ VÝROBKY / PRODOTTI STANDARD

Code Kód Codice	Size Velikost Taglia	Thread Závit Filetto	Filtration filtrace Filtrazione	Flow rate Průtok Portata	Regulation Régulation Regolazione	Exhaust Odvod koncentrátu Scarico
XS12231	1	1/4	20µm	1100NI/min	0 - 8bar	S/M
XS13231	1	3/8	20µm	1100NI/min	0 - 8bar	S/M
XS23231	2	3/8	20µm	2500NI/min	0 - 8bar	S/M
XS24231	2	1/2	20µm	2500NI/min	0 - 8bar	S/M
XS24232	2	1/2	20µm	2500NI/min	0 - 8bar	A
XS35231	3	3/4	20µm	4300NI/min	0 - 8bar	S/M
XS36231	3	1"	20µm	4300NI/min	0 - 8bar	S/M
XS36232	3	1"	20µm	4300NI/min	0 - 8bar	A

ORDERING CODE / OBJEDNÁVKOVÝ KÓD / CHIAVE DI CODIFICA

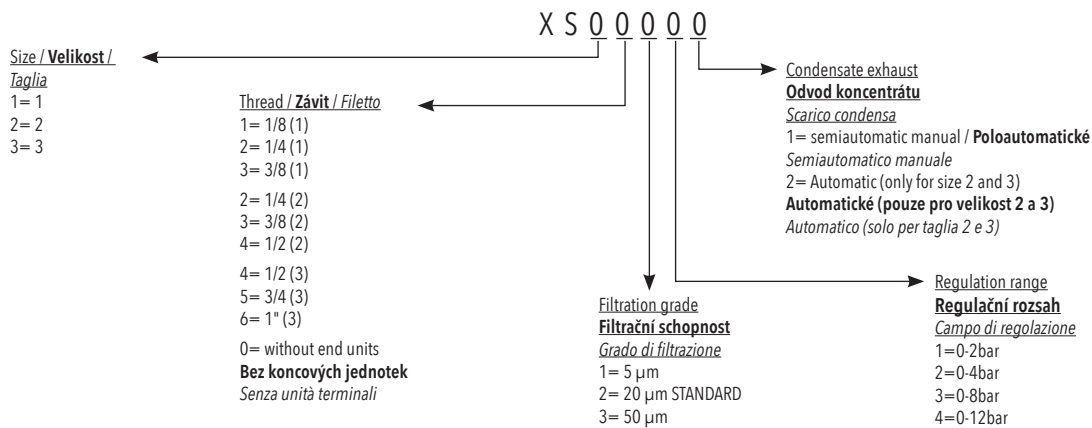

DIMENSIONS / ROZMĚRY / DIMENSIONI

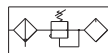
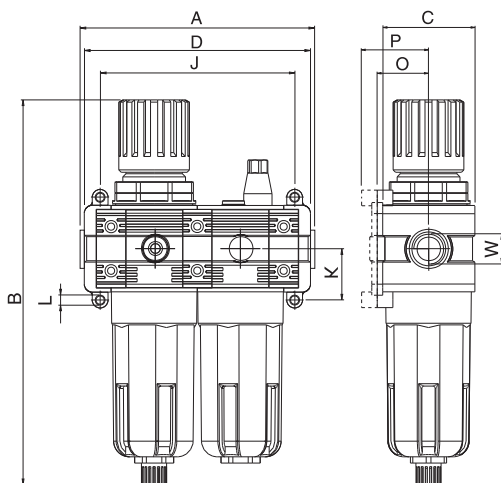

	Size / Velikost / Taglia		
	1	2	3
A	129	159	180
B	198	244,5	273
C	45	59	70
D	119	144	171 171 176
W	1/8-1/4-3/8	1/4-3/8-1/2	1/2-3/4-1"
J	97	124	144
K	26	32,5	38
L	Ø X M4	Ø X M5	Ø X M6
O	26	32	38,5
P	32,5	38,5	45



TECHNICAL DATA / TECHNICKÁ DATA / DATI TECNICI

Fluid / Tekutina / Fluido	Air / Vzduch / Aria		
Maximum pressure / Maximální tlak / Pressione Max	15 bar		
Temperature / Teplota / Temperatura	-10° C / +50° C		
Filtration grade / Filtrační schopnost / Grado di filtrazione	5 - 20 - 50µm		
6 bar flow rate with Δp 1bar / Průtok 6 barů s Δp 1bar Portata a 6 bar con Δp 1bar	1=1000 NI/min	2=2400NI/min	3=4250NI/min
Bowl capacity / Kapacita nádoby / Capacità tazza	1=22cm ³	2=46cm ³	3=89,5cm ³
Regulation range / Regulační rozsah / Campo di regolazione	0-2bar 0-4bar 0-8bar standard 0-12bar		
Wall clamping screws / Upínací šrouby na zed' / Viti per fissaggio	1=M4X14	2=M5X18	3=M6X20

STANDARD PRODUCTS / STANDARDNÍ VÝROBKY / PRODOTTI STANDARD

Code Kód Codice	Size Velikost Taglia	Thread Závit Filetto	Filtration filtrace Filtrazione	Flow rate Průtok Portata
XT122311	1	1/4	20µm	1000NI/min
XT132311	1	3/8	20µm	1000NI/min
XT232311	2	3/8	20µm	2400NI/min
XT242311	2	1/2	20µm	2400NI/min
XT352311	3	3/4	20µm	4250NI/min
XT362311	3	1"	20µm	4250NI/min

ORDERING CODE / OBJEDNÁVKOVÝ KÓD / CHIAVE DI CODIFICA

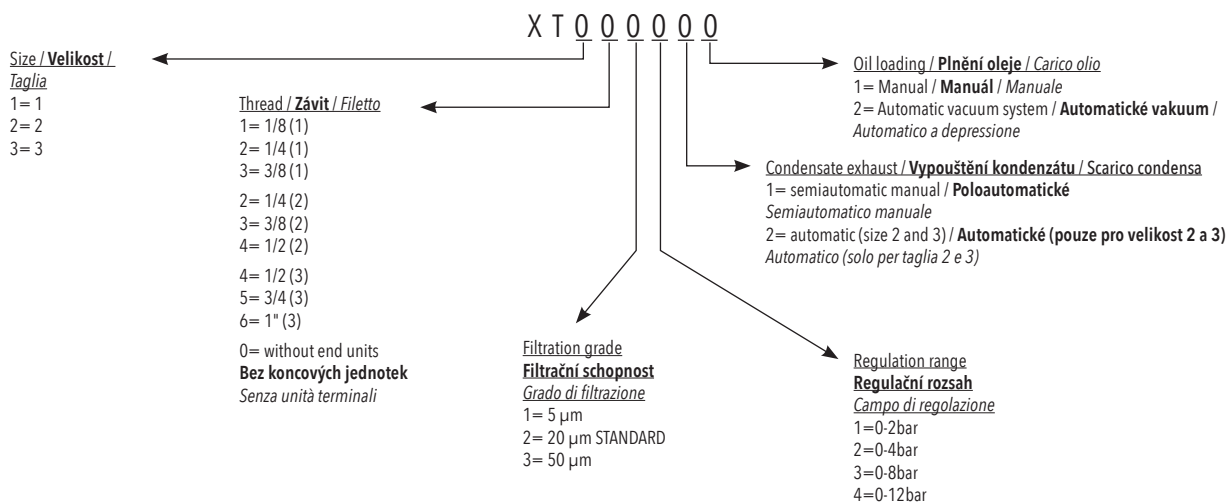

DIMENSIONS / ROZMĚRY / DIMENSIONI

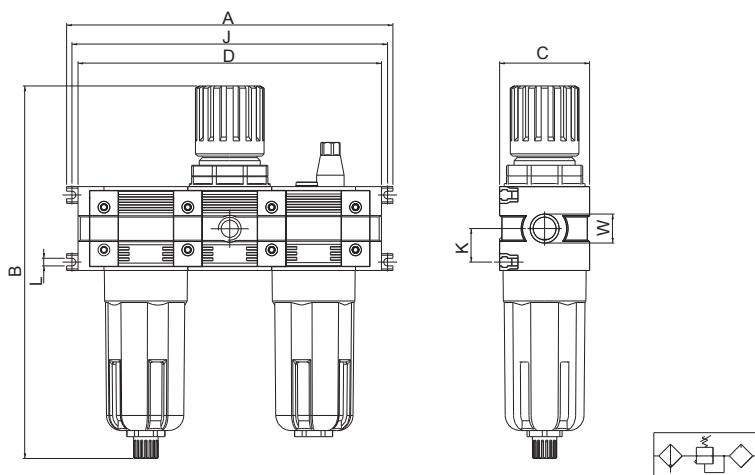

	Size / Velikost / Taglia		
	1	2	3
A	161,5	199	236
B	198	244,5	273
C	45	59	70
D	161,5	199	236 236 241
W	1/8-1/4-3/8	1/4-3/8-1/2	1/2-3/4-1"
J	140	179	209
K	26	32,5	38
L	Ø X M4	Ø X M5	Ø X M6
O	26	32	38,5
P	32,5	38,5	45

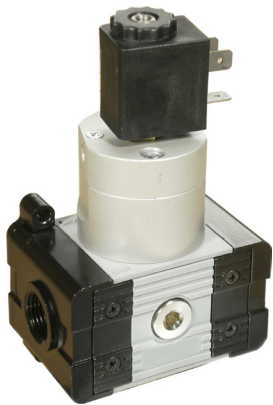

TECHNICAL DATA / TECHNICKÁ DATA / DATI TECNICI

Fluid / Tekutina / <i>Fluido</i>	Air / Vzduch / <i>Aria</i>		
Maximum pressure / Maximální tlak / <i>Pressione Max</i>	15 bar		
Temperature / Teplota / <i>Temperatura</i>	-10° C / +50° C		
6 bar flow rate with Δp 1bar / Průtok 6 barů s Δp 1bar / <i>Portata a 6 bar con Δp 1bar</i>	1=1850 NI/min	2=3000NI/min	3=5200NI/min
Wall clamping screws / Upínací šrouby na zeď / <i>Viti per fissaggio</i>	1=M4X14	2=M5X18	3=M6X20
Solenoid / Solenoid / <i>Solenoido</i>	24V DC 3W - 220V AC 5VA		

STANDARD PRODUCTS / STANDARDNÍ VÝROBKY / PRODOTTI STANDARD

Code Kód <i>Codice</i>	Size Velikost <i>Taglia</i>	Thread Závit <i>Filetto</i>	Drive Řídit <i>Comando</i>
XA1300	1	3/8	EP
XA2300	2	3/8	EP
XA2400	2	1/2	EP
XA3500	3	3/4	EP
XA3600	3	1"	EP

EP: Electropneumatic (without coil) / **Elektropneumatický (bez cívk)** / *Elettropneumatico (senza bobina)*

SIZE 1 / Velikost 1 / TAGLIA 1

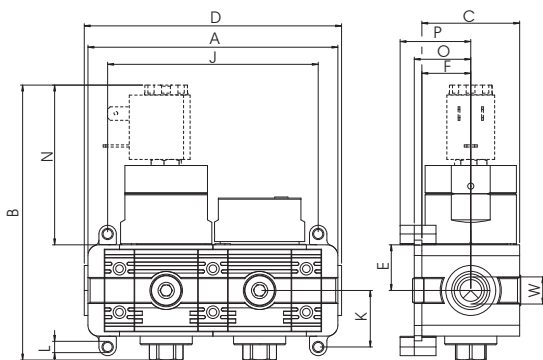

	1
A	118,5
B	126,5
C	45
D	115
W	1/8 - 1/4 - 3/8
E	21
F	22,5
J	97
K	26
L	Ø X M5
N	73,5
O	26
P	32,5

SIZE 2 - 3 / Velikost 2 - 3 / TAGLIA 2 - 3

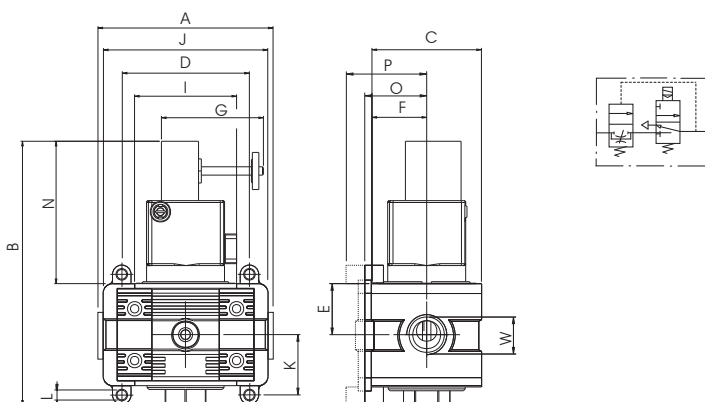

	2	3
A	89	106
B	142	131,5
C	59	70
D	89	100
W	1/4 - 3/8 - 1/2	1/2 - 3/4 - 1"
E	27,5	32,5
F	28,5	35
G	55,5	55,5
I	55	65
J	69	79
K	32,5	38
L	Ø X M5	Ø X M5
N	76,5	76,5
O	32	38,5
P	38,5	45



TECHNICAL DATA / TECHNICKÁ DATA / DATI TECNICI

Fluid / Tekutina / Fluido	Air / Vzduch / Aria		
Maximum pressure / Maximální tlak / Pressione Max	15 bar		
Temperature / Teplota / Temperatura	-10° C / +50° C		
6 bar flow rate with Δp 1bar / Průtok 6 barů s Δp 1bar Portata a 6 bar con Δp 1bar	1=1850 NI/min	2=3000NI/min	3=5200NI/min
Wall clamping screws / Upínací šrouby na zed' / Viti per fissaggio	1=M4X14	2=M5X18	3=M6X20
Solenoid / Solénoide / Solenoide	24V DC 3W - 220V AC 5VA		

STANDARD PRODUCTS / STANDARDNÍ VÝROBKY / PRODOTTI STANDARD

Code Kód Codice	Size Velikost Taglia	Thread Závit Filetto	Flow rate Průtok Portata	Drive Řídít Comando
XV121	1	1/4	1850NI/min	M
XV131	1	3/8	1850NI/min	M
XV132	1	3/8	1850NI/min	EP
XV133	1	3/8	1850NI/min	P
XV231	2	3/8	3000NI/min	M
XV241	2	1/2	3000NI/min	M
XV242	2	1/2	3000NI/min	EP
XV243	2	1/2	3000NI/min	P
XV351	3	3/4	5200NI/min	M
XV361	3	1"	5200NI/min	M
XV362	3	1"	5200NI/min	EP
XV363	3	1"	5200NI/min	P

M: Manual / Manuál / Manuale

P: Pneumatic / Pneumatický / Pneumatico

EP: Electropneumatic (without coil) / Elektropneumatický (bez cívky) / Elettropneumatico (senza bobina)

MANUAL / Manuál / MANUALE

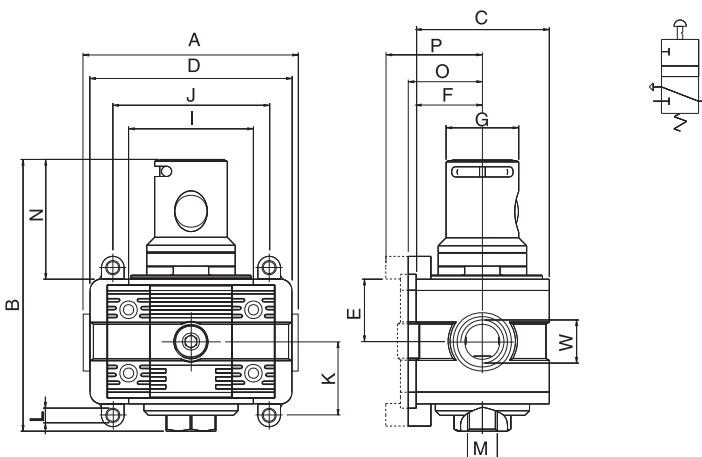

	Size / Velikost / Taglia		
	1	2	3
A	75,5	89	100
B	105,5	119,5	131,5
C	45	59	70
D	72	89	106 106 111
W	1/8 - 1/4 - 3/8	1/4 - 3/8 - 1/2	1/2 - 3/4 - 1"
E	21	27,5	32,5
F	22,5	28,5	35
G	32	32	32
I	43	55	65
J	54	69	79
K	26	32,5	38
L	Ø X M4	Ø X M5	Ø X M6
M	1/8	1/4	3/8
N	52,5	52,5	52,5
O	26	32	38,5
P	32,5	38,5	45

PNEUMATIC / Pneumatický / PNEUMATICO

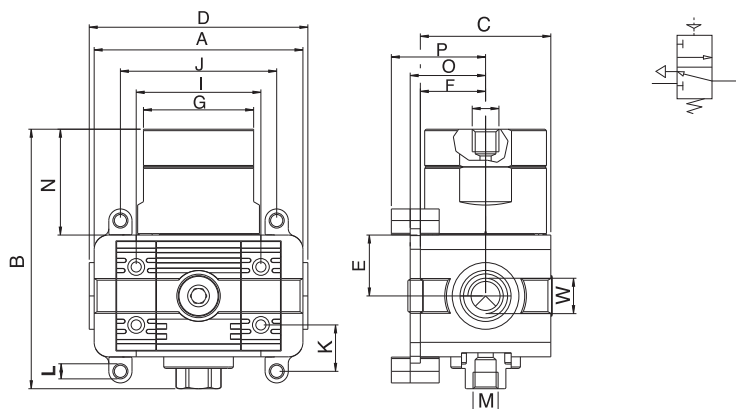

	Size / Velikost / Taglia		
	1	2	3
A	75,5	89	106
B	89,5	100,5	108
B1	126,5	137,5	144,9
C	45	59	70
D	72	89	100
W	1/8 - 1/4 - 3/8	1/4 - 3/8 - 1/2	1/2 - 3/4 - 1"
E	21	27,5	32,5
F	22,5	28,5	35
G	38	38	38
I	43	55	65
J	54	69	79
K	16	32,5	38
L	Ø X M4	Ø X M5	Ø X M6
M	1/8	1/4	3/8
N	36,5	32,7	29
N1	73,5	69,6	65,9
O	26	32	38,5
P	32,5	38,5	45
Q	1/8	1/8	1/8

ELETTROPNEUMATIC / ELECTRO Pneumatický / ELETTROPNEUMATICO

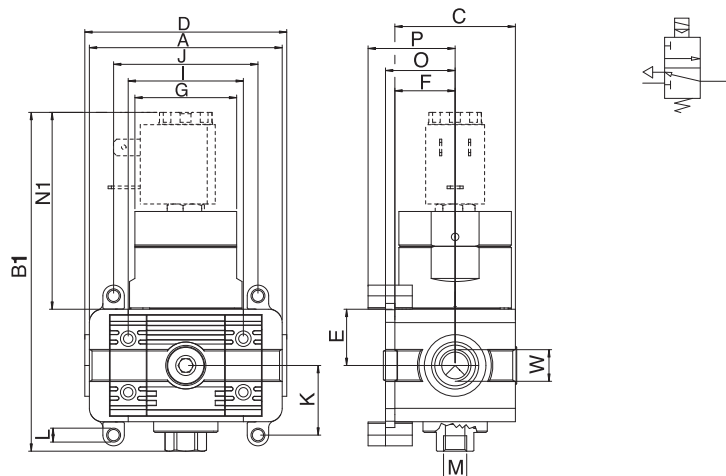

	Size / Velikost / Taglia		
	1	2	3
A	75,5	89	106
B	89,5	100,5	108
B1	126,5	137,5	144,9
C	45	59	70
D	72	89	100
W	1/8 - 1/4 - 3/8	1/4 - 3/8 - 1/2	1/2 - 3/4 - 1"
E	21	27,5	32,5
F	22,5	28,5	35
G	38	38	38
I	43	55	65
J	54	69	79
K	16	32,5	38
L	Ø X M4	Ø X M5	Ø X M6
M	1/8	1/4	3/8
N	36,5	32,7	29
N1	73,5	69,6	65,9
O	26	32	38,5
P	32,5	38,5	45
Q	1/8	1/8	1/8



TECHNICAL DATA / TECHNICKÁ DATA / DATI TECNICI

Fluid / Tekutina / Fluido	Air / Vzduch / Aria		
Maximum pressure / Maximální tlak / Pressione Max	15 bar		
Temperature / Teplota / Temperatura	-10° C / +50° C		
Filtration grade / Filtrační schopnost / Grado di filtrazione	5 - 20 - 50µm		
6 bar flow rate with Δp 1bar / Průtok 6 barů s Δp 1bar Portata a 6 bar con Δp 1bar	1=1350 NI/min	2=3200NI/min	3=5000NI/min
Bowl capacity / Kapacita nádoby / Capacità tazza	1=22cm ³	2=46cm ³	3=89,5cm ³
Wall clamping screws / Upínací šrouby na zed' / Viti per fissaggio	1=M4X14	2=M5X18	3=M6X20

STANDARD PRODUCTS / STANDARDNÍ VÝROBKY / PRODOTTI STANDARD

Code Kód Codice	Size Velikost Taglia	Thread Závit Filetto	Filtration filtrace Filtrazione	Flow rate Průtok Portata	S/M: Semi automatic Manual / Poloaufomatický / manuální / Semiautomatico Manuale A: Automatic / Automatický / Automatico
X0122011	1	1/4	20µm	1350NI/min	
X0132011	1	3/8	20µm	1350NI/min	
X0232011	2	3/8	20µm	3200NI/min	
X0242011	2	1/2	20µm	3200NI/min	
X0352011	3	3/4	20µm	5000NI/min	
X0362011	3	1"	20µm	5000NI/min	

ORDERING CODE / OBJEDNÁVKOVÝ KÓD / CHIAVE DI CODIFICA

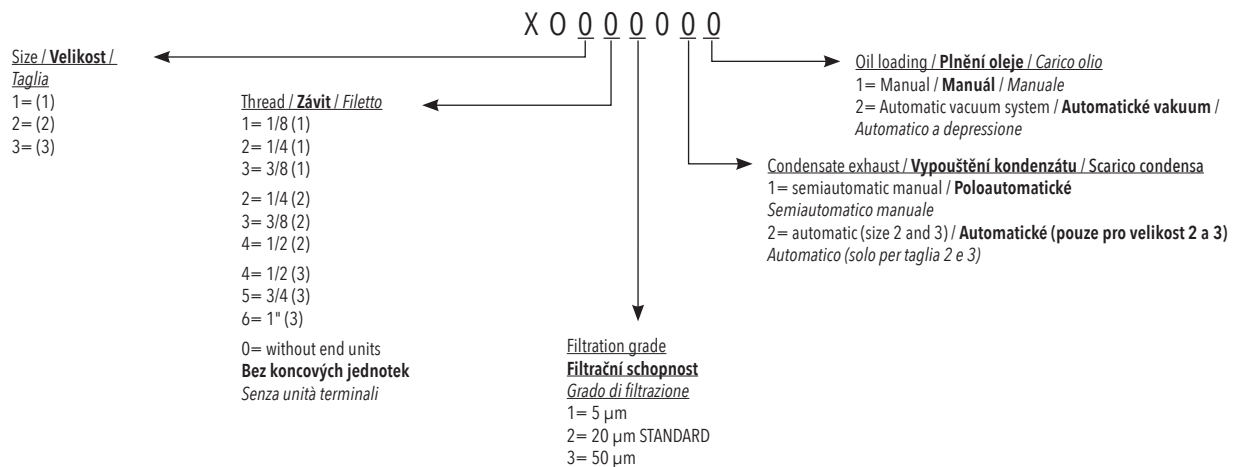

DIMENSIONS / ROZMĚRY / DIMENSIONI

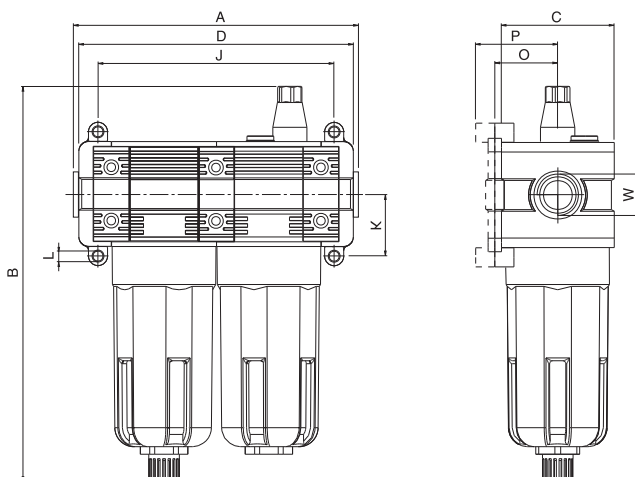

	A	B	C	D	W	J	K	L	O	P
Size 1	118,5	175	45	115	1/8-1/4-3/8	97	26	M4	26	32,5
Size 2	144	207,5	59	144	1/4-3/8-1/2	124	32,5	M5	32	38,5
Size 3	171	226,5	70	165	1/2-3/4-1	144	38	M6	38,5	45



TECHNICAL DATA / TECHNICKÁ DATA / DATI TECNICI

Fluid / Tekutina / Fluido	Air / Vzduch / Aria		
Maximum pressure / Maximální tlak / Pressione Max	15 bar		
Temperature / Teplota / Temperatura	-10° C / +50° C		
Temperature / Temperatura / Temperatura	5µm + 0.01µm		
6 bar flow rate with Δp 1bar / Průtok 6 barů s Δp 1bar / Portata a 6 bar con Δp 1bar	1=600 NI/min	2=660 NI/min	3=910 NI/min
Bowl capacity / Kapacita nádobky / Capacità tazza	1=22cm ³	2=46cm ³	3=89,5cm ³
Wall clamping screws / Upínací šrouby na zeď / Viti per fissaggio	1=M4X14	2=M5X18	3=M6X20

STANDARD PRODUCTS / STANDARDNÍ VÝROBKY / PRODOTTI STANDARD

Code Kód Codice	Size Velikost Taglia	Thread Závit Filetto	Filtration filtrace Filtrazione	Flow rate Průtok Portata
XD1201	1	1/4	5µm + 0.01µm	600NI/min
XD1301	1	3/8	5µm + 0.01µm	600NI/min
XD2301	2	3/8	5µm + 0.01µm	660NI/min
XD2401	2	1/2	5µm + 0.01µm	660NI/min
XD3501	3	3/4	5µm + 0.01µm	910NI/min
XD3601	3	1"	5µm + 0.01µm	910NI/min

DIMENSIONS / ROZMĚRY / DIMENSIONI

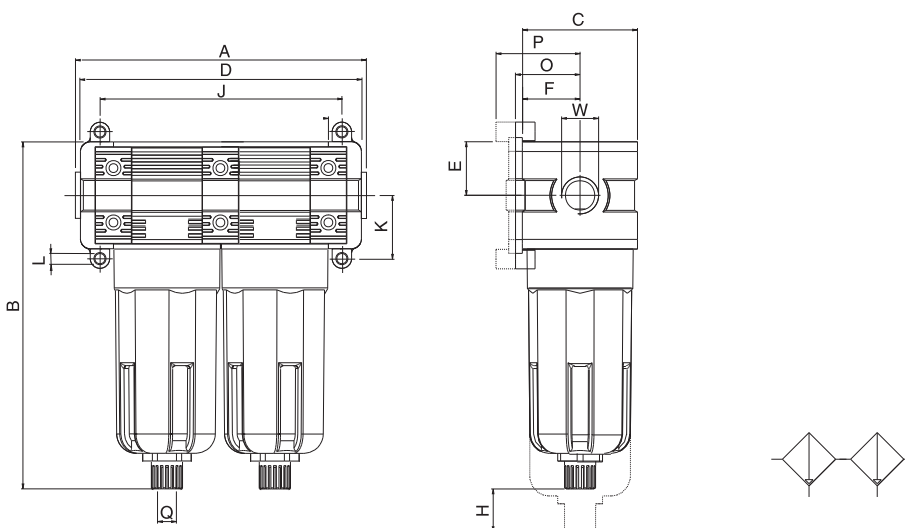

	A	B	C	D	W	E	F	H	I	J	K	L	O	P	Q
Size 1	118,5	146	45	115	1/8-1/4-3/8	21	22,5	39	43	97	26	M4	26	32,5	1/8-
Size 2	144	178,5	59	144	1/4-3/8-1/2	27,5	28,5	48	55	124	32,5	M5	32	38,5	1/8
Size 3	171	197,5	70	165	1/2-3/4-1	32,5	35	50	65	144	38	M6	38,5	45	1/8

INFORMACES / INFORMACE / INFORMAZIONE

La kazeta coalescence est constituée d'une couche de micro-fibres soutenues par une structure externe en acier inoxydable. La kazeta de coalescence, en exploitant les principes de l'impaction inertielle, l'interception et la coalescence, oblige les particules de liquide qui le traversent pour se joindre à former de plus grandes microgouttes qui, par gravité, d'un précipité au fond du récipient. Le filtrační kroužek à coalescence utilisé en tant que séparateur permet d'obtenir une sortie d'air exempt d'oporučený olej. Nous recommandons d'installer en amont du filtrační kroužek de coalescence, un filtrační kroužek 5 µm qui retient les particules solides évitant ainsi le colmatage de la kazeta de coalescence.

La kazeta à coalescence est constituée d'une couche de micro-fibres avec une structure externe en acier inoxydable. La kazeta à coalescence utilise l'impact inertielle, l'interception et la coalescence pour recueillir les particules liquides en fines gouttes. Ces gouttes tomberont dans le fond du miska. Le filtrační kroužek à coalescence est utilisé comme séparateur d'oporučený olej pour éliminer les vapeurs d'oporučený olej de la sortie d'air.

La cartuccia a coalescenza è costituita da uno strato di microfibre sorrette da una struttura esterna in acciaio inox. La cartuccia a coalescenza, sfruttando i principi dell'impatto inerziale, dell'intercettazione e della coalescenza, obbliga le particelle di liquido che l'attraversano ad unirsi formando microgocce più grandi che, per gravità, precipitano sul fondo del contenitore. Il filtro a coalescenza usato come disoleatore permette di ottenere un'aria in uscita priva di olio. Si consiglia di montare a monte del filtro a coalescenza un filtro da 5 µm che trattenga le particelle solide evitando così l'intasamento della cartuccia a coalescenza.

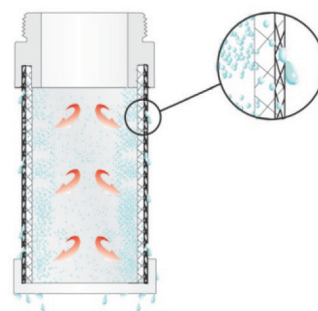



TECHNICAL DATA / TECHNICKÁ DATA / DATI TECNICI

Fluid / Tekutina / Fluido	Air / Vzduch / Aria		
Maximum pressure / Maximální tlak / Pressione Max	15 bar		
Temperature / Teplota / Temperatura	-10° C / +50° C		
6 bar flow rate with Δp 1bar / Průtok 6 barů s Δp 1bar Portata a 6 bar con Δp 1bar	1=800 NI/min	2=2100NI/min	3=3500NI/min
Wall clamping screws / Upínací šrouby na zeď / Viti per fissaggio	1=M4X14	2=M5X18	3=M6X20
Bowl capacity / Kapacita nádoby / Capacità tazza	1=22cm ³	2=46cm ³	3=89,5cm ³

STANDARD PRODUCTS / STANDARDNÍ VÝROBKY / PRODOTTI STANDARD

Code Kód Codice	Size Velikost Taglia	Thread Závit Filetto	Filtration filtrace Filtrazione	Flow rate Průtok Portata	Regulation Régulation Regolazione
XM122311	1	1/4	20µm	800NI/min	0 - 8bar
XM132311	1	3/8	20µm	800NI/min	0 - 8bar
XM232311	2	3/8	20µm	2100NI/min	0 - 8bar
XM242311	2	1/2	20µm	2100NI/min	0 - 8bar
XM352311	3	3/4	20µm	3500NI/min	0 - 8bar
XM362311	3	1"	20µm	3500NI/min	0 - 8bar

ORDERING CODE / OBJEDNÁVKOVÝ KÓD / CHIAVE DI CODIFICA

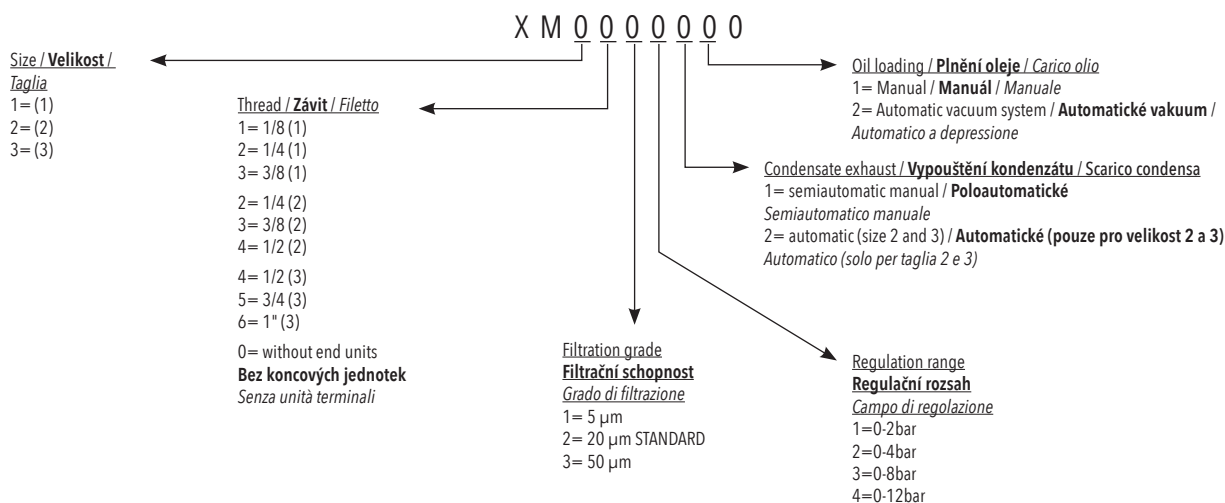

DIMENSIONS / ROZMĚRY / DIMENSIONI

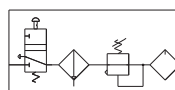
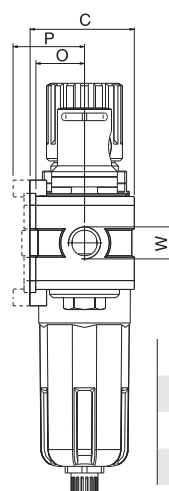
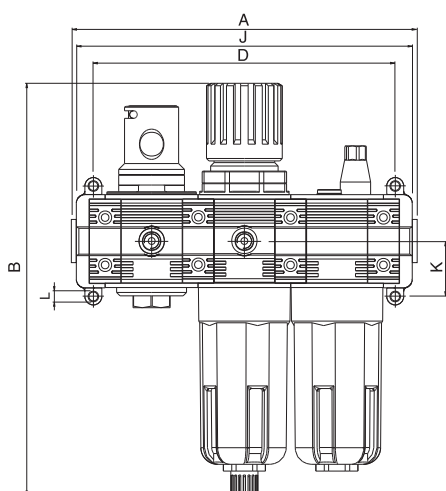

	A	B	C	D	W	J	K	L	O	P
Size 1	115	198	45	118,5	1/8-1/4-3/8	140	26	M4	26	32,5
Size 2	144	244,5	59	199	1/4-3/8-1/2	179	32,5	M5	32	38,5
Size 3	165	273	70	230	1/2-3/4-1	209	38	M6	38,5	45



TECHNICAL DATA / TECHNICKÁ DATA / DATI TECNICI

Fluid / Tekutina / Fluido	Air / Vzduch / Aria		
Maximum pressure / Maximální tlak / Pressione Max	15 bar		
Temperature / Teplota / Temperatura	-10° C / +50° C		
Filtration grade / Filtrační schopnost / Grado di filtrazione	5 - 20 - 50µm		
6 bar flow rate with Δp 1bar / Průtok 6 barů s Δp 1bar / Portata a 6 bar con Δp 1bar	1=1000 NI/min	2=2200NI/min	3=3900NI/min
Bowl capacity / Kapacita nádobky / Capacità tazza	1=22cm ³	2=46cm ³	3=89,5cm ³
Regulation range / Campo di regolazione	0-2bar 0-4bar 0-8bar standard 0-12bar		
Wall clamping screws / Upínací šrouby na zeď / Viti per fissaggio	1=M4X14	2=M5X18	3=M6X20

STANDARD PRODUCTS / STANDARDNÍ VÝROBKY / PRODOTTI STANDARD

Code Kód Codice	Size Velikost Taglia	Thread Závít Filetto	Filtration filtrace Filtrazione	Flow rate Průtok Portata
XN122311	1	1/4	20µm	1000NI/min
XN132311	1	3/8	20µm	1000NI/min
XN232311	2	3/8	20µm	2200NI/min
XN242311	2	1/2	20µm	2200NI/min
XN352311	3	3/4	20µm	3900NI/min
XN362311	3	1"	20µm	3900NI/min

S/M: Semi automatic Manual / **Manuál semiautomatický** /
 Semiautomatico Manuale
 A: Automatic / **Automatický** / Automatico

ORDERING CODE / OBJEDNÁVKOVÝ KÓD / CHIAVE DI CODIFICA

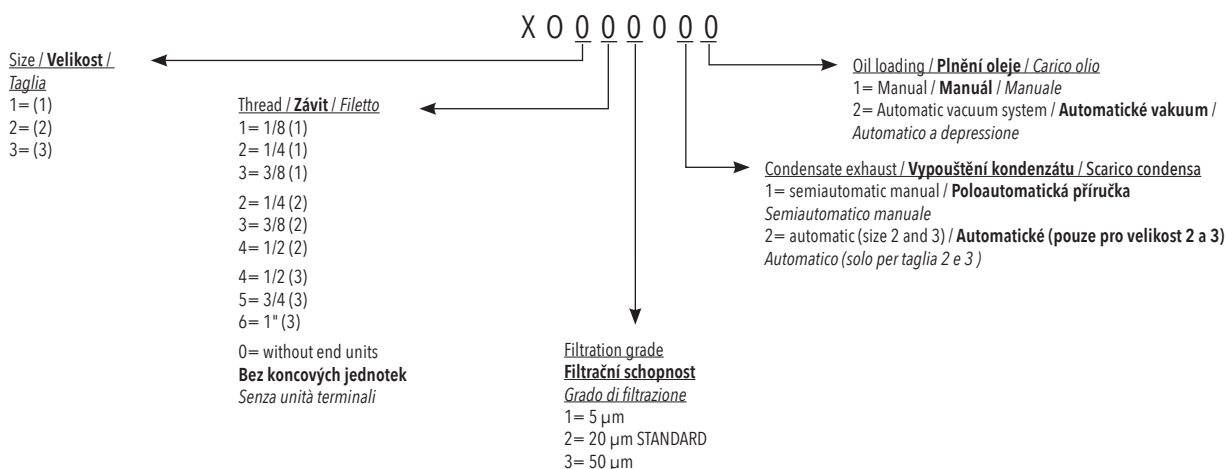

DIMENSIONS / ROZMĚRY / DIMENSIONI

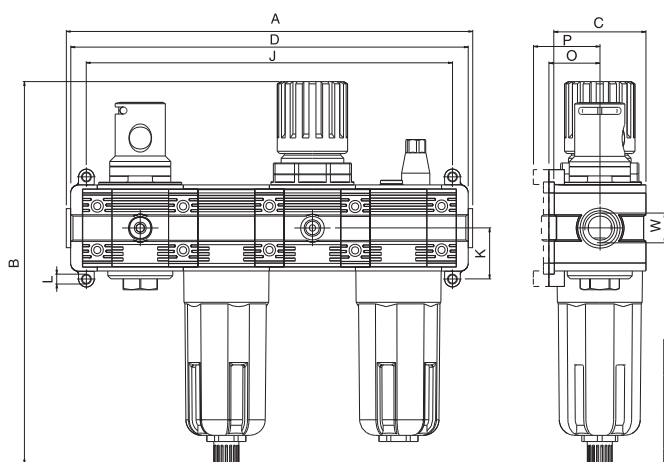

	A	B	C	D	W	J	K	L	O	P
Size 1	201	198	45	204,5	1/8-1/4-3/8	183	26	M4	48,5	55
Size 2	254	244,5	59	254	1/4-3/8-1/2	234	32,5	M5	62,5	69
Size 3	295	273	70	301	1/2-3/4-1	274	38	M6	73,5	80

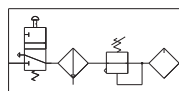

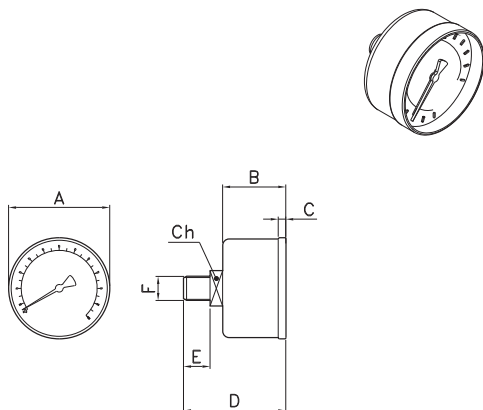

PRESSURE GAUGE BACK CONNECTION
MANOMETR ZADNÍ PŘIPOJENÍ
MANOMETRO ATTACCO POSTERIORE

CODE	SIZE	REG.
XB1712	D.40 1/8	0-4 bar
XB1716	D.40 1/8	0-6 bar
XB1715	D.40 1/8	0-10 bar
XB1714	D.40 1/8	0-12 bar
XB2116	D.50 1/8	0-6 bar
XB2114	D.50 1/8	0-12 bar

Ø	A	B	C	D	E	F	CH
40	40	25	3	41.5	10	G1/8	12
50	50	26	3.8	47	13	G1/8	14

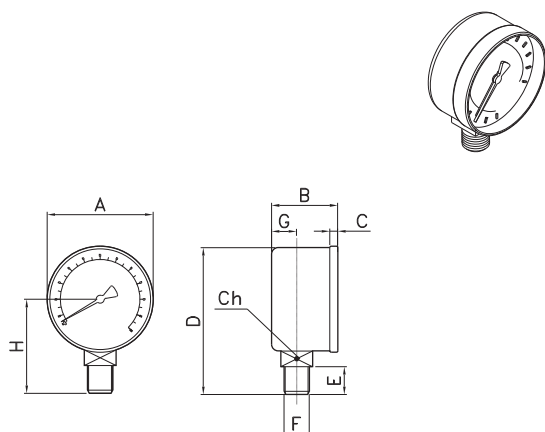

PRESSURE GAUGE BOTTOM CONNECTION
MANOMETR SPODNÍ PŘIPOJENÍ
MANOMETRO ATTACCO RADIALE

CODE	SIZE	REG.
XB2216	D.40 1/8	0-6 bar
XB2214	D.40 1/8	0-12 bar
XB2314	D.50 1/8	0-12 bar

Ø	A	B	C	D	E	F	G	H	CH
40	40	23.5	3	56	10	G1/8	9.5	36	12
50	50	26	3.8	70	13	G1/8	10.3	45	14

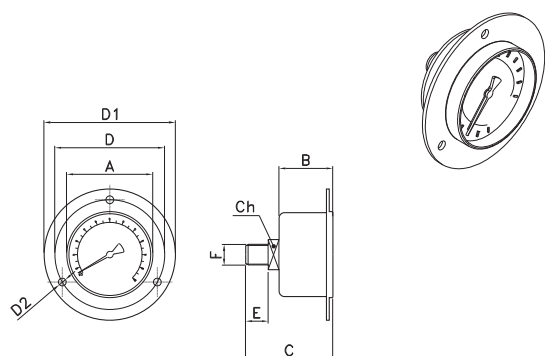

PRESSURE GAUGE 3 HOLE FLANGE
MANOMETR DO PANELU
MANOMETRO FLANGIA A 3 FORI

CODE	SIZE	REG.
XB2412	D.40 1/8	0-4 bar
XB2416	D.40 1/8	0-6 bar
XB2415	D.40 1/8	0-10 bar
XB2414	D.40 1/8	0-12 bar

Ø	A	B	C	D	D1	D2	E	F	CH
40	40	26	42.5	51	61	3.6	10	G1/8	12

CONNECTION PLATE / SPOJOVACÍ SADA / PIATRINA DI COLLEGAMENTO



CODE	SIZE
XB0100	0
XB0110	1
XB0120	2
XB0130	3

ENDS UNIT / JEDNOTKA UKONČOVACÍ / GRUPPO TERMINALI



CODE	SIZE
XB0211	1 1/8
XB0212	1 1/4
XB0213	1 3/8
XB0222	2 1/4
XB0223	2 3/8
XB0224	2 1/2
XB0234	3 1/2
XB0233	3 3/4
XB0236	3 1"

CONNECTION UNIT / SPOJOVACÍ JEDNOTKA / GRUPPO DI COLLEGAMENTO

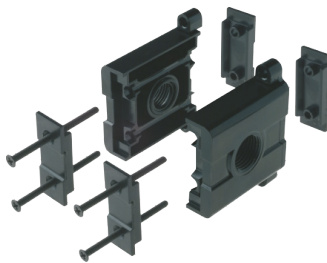

CODE	SIZE
XB0311	1 1/8
XB0312	1 1/4
XB0313	1 3/8
XB0322	2 1/4
XB0323	2 3/8
XB0324	2 1/2
XB0334	3 1/2
XB0333	3 3/4
XB0336	3 1"

FILTER RING DEVICE / DRŽÁK S FILTREM / GRUPPO PORTAFILTRO



CODE	SIZE
XB0801	0 5 µm
XB0802	0 20 µm
XB0803	0 50 µm
XB0811	1 5 µm
XB0812	1 20 µm
XB0813	1 50 µm
XB0821	2 5 µm
XB0822	2 20 µm
XB0823	2 50 µm
XB0831	3 5 µm
XB0832	3 20 µm
XB0833	3 50 µm

MEMBRÁNA UNIT / MEMBRÁNA / GRUPPO MEMBRANA



CODE	SIZE
XB1800	0
XB1810	1
XB1820	2
XB1830	3

REGISTER SPRING / PRUŽINA / MOLLA DI REGISTRO



CODE	SIZE
XB1201	0 0-2 bar
XB1202	0 0-4 bar
XB1203	0 0-8 bar
XB1204	0 0-12 bar
XB1211	1 0-2 bar
XB1212	1 0-4 bar
XB1213	1 0-8 bar
XB1214	1 0-12 bar
XB1221	2 0-2 bar
XB1222	2 0-4 bar
XB1223	2 0-8 bar
XB1224	2 0-12 bar
XB1231	3 0-2 bar
XB1232	3 0-4 bar
XB1233	3 0-8 bar
XB1234	3 0-12 bar

VENTURI UNIT / JEDNOTKA VENTURI / GRUPPO VENTURI



CODE	SIZE
XB0900	0
XB0910	1
XB0920	2
XB0930	3

OIL FEEDING DEVICE / HLEDÍTKO K MAZNICI / GRUPPO DOSATORE OLIO



CODE	SIZE
XB1000	0
XB1010	1
XB1020	2
XB1030	3

REGULATING DEVICE / REGULAČNÍ ZAŘÍZENÍ / GRUPPO DI REGOLAZIONE



CODE	SIZE
XB1101	0 0-2 bar
XB1102	0 0-4 bar
XB1103	0 0-8 bar
XB1104	0 0-12 bar
XB1111	1 0-2 bar
XB1112	1 0-4 bar
XB1113	1 0-8 bar
XB1114	1 0-12 bar
XB1121	2 0-2 bar
XB1122	2 0-4 bar
XB1123	2 0-8 bar
XB1124	2 0-12 bar
XB1131	3 0-2 bar
XB1132	3 0-4 bar
XB1133	3 0-8 bar
XB1134	3 0-12 bar

REGULATING PLUG UNIT / REGULACE PLUGOVÉ JEDNOTKY



CODE	SIZE
XB1300	0
XB1310	1
XB1320	2
XB1330	3

SHUTTER + FILTER UNIT / JEDNOTKA + FILTROVÁ JEDNOTKA



CODE	SIZE
XB1501	0 5 µm
XB1502	0 20 µm
XB1503	0 50 µm
XB1511	1 5 µm
XB1512	1 20 µm
XB1513	1 50 µm
XB1521	2 5 µm
XB1522	2 20 µm
XB1523	2 50 µm
XB1531	3 5 µm
XB1532	3 20 µm
XB1533	3 50 µm

SINTERED FILTER / SINTEROVANÝ FILTR / FILTRO SINTERIZZATO



CODE	SIZE
XB1601	0 5 µm
XB1602	0 20 µm
XB1603	0 50 µm
XB1611	1 5 µm
XB1612	1 20 µm
XB1613	1 50 µm
XB1621	2 5 µm
XB1622	2 20 µm
XB1623	2 50 µm
XB1631	3 5 µm
XB1632	3 20 µm
XB1633	3 50 µm

AIR DISTRIBUTOR / ROZBOČOVACÍ KOSTKA / DISTRIBUTORE D'ARIA

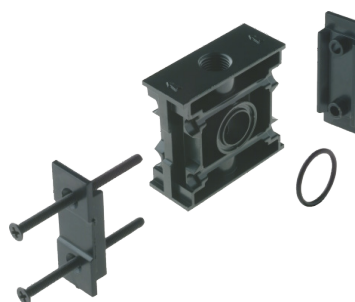

CODE	SIZE
XB1400	0
XB1410	1
XB1420	2
XB1430	3

CLAMP BRACKET / UPEVŇOVACÍ ČLEN / STAFFA DI FISSAGGIO

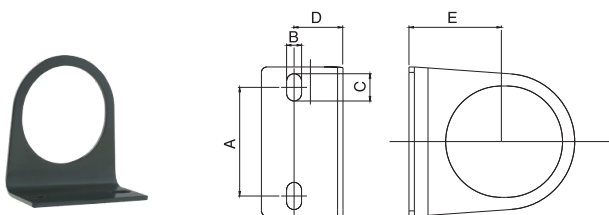

CODE	SIZE	A	B	C	D	E
XB1900	0	21,5	5,5	12	15	31
XB1910	1	28	5,5	10	15	29
XB1920	2	40	5,5	10	18	35
XB1930	3	50	5,5	10	20	39

COIL / CÍVKA / BOBINA



CODE	SIZE
XB2010	24V DC 3W
XB2020	220V AC 5VA

BOWL FOR FILTER UNIT / NÁDOBKA FILTRU
GRUPPO TAZZA FILTRO



CODE	SIZE
XB0400	0
XB0410	1
XB0420	2
XB0430	3

BOWL FOR AUTOMATIC CONDENSED EXHAUST / NÁDOBKA FILTRU S AUTOMATEM /
GRUPPO TAZZA SCARICO CONDENSA AUTOMATICO



CODE	SIZE
XB0520	2
XB0530	3

BOWL FOR LUBRICATOR UNIT / NÁDOBKA K MAZNICI / GRUPPO TAZZA
LUBRIFICATORE



CODE	SIZE
XB0600	0
XB0610	1
XB0620	2
XB0630	3

BOWL FOR AUTOMATIC OIL LOADING SYSTEM / NÁDOBKA PRO AUTOMATICKÉ
PLNĚNÍ OLEJE / GRUPPO TAZZA CARICAMENTO AUTOMATICO OLIO



CODE	SIZE
XB0710	1
XB0720	2
XB0730	3

