

















POS mounting accessories cover all market needs as they're available in three different materials: aluminium (lighter and cost-effective), steel (to guarantee an extraordinary mechanical resistance) and stainless steel (specially re-quired in specific markets as pharmaceutical and food industry, and in extremely harsh environments in the presence of sea water or acids).

Montážní příslušenství POS pokrývá všechny potřeby trhu, protože jsou k dispozici ve třech různých materiálech: hliník (lehčí a cenově výhodný), ocel (zaručující mimořádnou mechanickou odolnost) a nerezová ocel (speciálně požadovaná na konkrétních trzích jako farmaceutický a potravinářský průmysl) průmyslu a v extrémně drsném prostředí v přítomnosti mořské vody nebo kyselin).

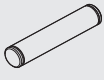
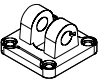
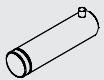
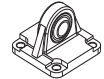
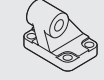
Gli accessori della gamma POS rispondono a tutte le esigenze avendo a disposizione fissaggi di tre materiali diversi: Alluminio per agevolare la leggerezza e il costo, l'acciaio per garantire estrema resistenza meccanica, e acciaio inox per esigenze di applicazioni in ambienti come l'alimentare o il farmaceutico oppure estremamente aggressivi come presenza di acqua di mare o acidi.

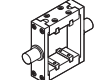
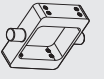
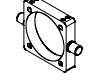
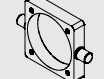
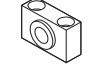
		Cyl.	Material	Ø8-10	Ø12-16	Ø20-25	Ø32	Ø40	Ø50	Ø63	Ø80	Ø100	Ø125	Ø160	Ø200	Ø250
	PEDESTAL BOČNÍ PATKA PIEDINO	MC	Aluminium	-	-	-	-	-	-	-	-	-	-	-	-	-
			Steel	pag.1.10	pag.1.10	pag.1.10	-	-	-	-	-	-	-	-	-	-
			Stainless steel	pag.1.16	pag.1.16	pag.1.16	-	-	-	-	-	-	-	-	-	-
	FLANGE ČELNÍ (ZADNÍ) DESKA FLANGIA	MC	Aluminium	-	-	-	-	-	-	-	-	-	-	-	-	-
			Steel	pag.1.10	pag.1.10	pag.1.10	-	-	-	-	-	-	-	-	-	
			Stainless steel	pag.1.16	pag.1.16	pag.1.16	-	-	-	-	-	-	-	-	-	
	FEMALE HINGE ZADNÍ KYVNÉ LOŽISKO CERNIERA FEMMINA	MC	Aluminium	-	-	-	-	-	-	-	-	-	-	-	-	-
			Steel	pag.1.10	pag.1.10	pag.1.10	-	-	-	-	-	-	-	-	-	
			Stainless steel	pag.1.16	pag.1.16	pag.1.16	-	-	-	-	-	-	-	-	-	
	PEDESTAL BOČNÍ PATKA PIEDINO	CT	Aluminium	-	-	-	-	-	-	-	-	-	-	-	-	-
			Steel	-	-	-	pag.1.22	pag.1.22	pag.1.22	pag.1.22	-	-	-	-	-	
			Stainless steel	-	-	-	-	-	-	-	-	-	-	-	-	
	FEMALE HINGE ZADNÍ KYVNÉ LOŽISKO CERNIERA FEMMINA	CT	Aluminium	-	-	-	-	-	-	-	-	-	-	-	-	-
			Steel	-	-	-	pag.1.22	pag.1.22	pag.1.22	pag.1.22	-	-	-	-	-	
			Stainless steel	-	-	-	-	-	-	-	-	-	-	-	-	
	PIVOT FOR HINGE PIN PRO ZÁVĚS PERNI PER CERNIERA	CT	Aluminium	-	-	-	-	-	-	-	-	-	-	-	-	-
			Steel	-	-	-	pag.1.22	pag.1.22	pag.1.22	pag.1.22	-	-	-	-	-	
			Stainless steel	-	-	-	-	-	-	-	-	-	-	-	-	
	PEDESTAL BOČNÍ PATKA PIEDINO	CY CZ CQ	Aluminium	-	-	-	-	-	-	-	-	-	-	-	-	-
			Steel	-	-	-	pag.1.51	pag.1.51	pag.1.51	pag.1.51	pag.1.51	pag.1.51	pag.1.51	pag.1.51	pag.1.51	
			Stainless steel	-	-	-	pag.1.67	pag.1.67	pag.1.67	pag.1.67	pag.1.67	pag.1.67	pag.1.67	-	-	
	FLANGE ČELNÍ (ZADNÍ) DESKA FLANGIA	CY CZ CQ	Aluminium	-	-	-	-	-	-	-	-	-	-	-	-	-
			Steel	-	-	-	pag.1.51	pag.1.51	pag.1.51	pag.1.51	pag.1.51	pag.1.51	pag.1.51	pag.1.51	pag.1.51	
			Stainless steel	-	-	-	pag.1.67	pag.1.67	pag.1.67	pag.1.67	pag.1.67	pag.1.67	pag.1.67	-	-	
	MALE HINGE ZADNÍ KYVNÉ OKO CERNIERA MASCHIO	CY CZ CQ	Aluminium	-	-	-	pag.1.51	pag.1.51	pag.1.51	pag.1.51	pag.1.51	pag.1.51	pag.1.51	pag.1.51	pag.1.51	pag.1.51
			Steel	-	-	-	pag.1.52	pag.1.52	pag.1.52	pag.1.52	pag.1.52	pag.1.52	pag.1.52	pag.1.52	pag.1.52	
			Stainless steel	-	-	-	pag.1.67	pag.1.67	pag.1.67	pag.1.67	pag.1.67	pag.1.67	pag.1.67	-	-	
	FEMALE HINGE ZADNÍ KYVNÉ LOŽISKO CERNIERA FEMMINA	CY CZ CQ	Aluminium	-	-	-	pag.1.52	pag.1.52	pag.1.52	pag.1.52	pag.1.52	pag.1.52	pag.1.52	pag.1.52	pag.1.52	pag.1.52
			Steel	-	-	-	pag.1.52	pag.1.52	pag.1.52	pag.1.52	pag.1.52	pag.1.52	pag.1.52	pag.1.52	pag.1.52	
			Stainless steel	-	-	-	pag.1.67	pag.1.67	pag.1.67	pag.1.67	pag.1.67	pag.1.67	pag.1.67	-	-	

	PIVOT FOR HINGE ČEP PERNO PER CERNIERA	CY CZ CQ	Aluminium	-	-	-	-	-	-	-	-	-	-	-	-	-	
			Steel	-	-	-	pag.1.53	pag.1.53	pag.1.53	pag.1.53	pag.1.53	pag.1.53	pag.1.53	pag.1.53	pag.1.53	pag.1.53	pag.1.53
			Stainless steel	-	-	-	pag.1.68	pag.1.68	pag.1.68	pag.1.68	pag.1.68	pag.1.68	pag.1.68	pag.1.68	-	-	-
	NARROW FEMALE HINGE ZADNÍ KYVNÉ LOŽISKO CERNIERA FEM. STRETTA	CY CZ CQ	Aluminium	-	-	-	-	-	-	-	-	-	-	-	-	-	
			Steel	-	-	-	pag.1.53	pag.1.53	pag.1.53	pag.1.53	pag.1.53	pag.1.53	pag.1.53	pag.1.53	pag.1.53	pag.1.53	pag.1.53
			Stainless steel	-	-	-	-	-	-	-	-	-	-	-	-	-	-
	PIVOT ANTI-ROTATION ČEP ANTIROTAČNÍ PERNO ANTIROTAZIONE	CY CZ CQ	Aluminium	-	-	-	-	-	-	-	-	-	-	-	-	-	
			Steel	-	-	-	pag.1.54	pag.1.54	pag.1.54	pag.1.54	pag.1.54	pag.1.54	pag.1.54	pag.1.54	pag.1.54	pag.1.54	pag.1.54
			Stainless steel	-	-	-	-	-	-	-	-	-	-	-	-	-	-
	MALE HINGE ART. HEAD ZADNÍ KYVNÉ OKO CERNIERA MAS. SNODATA	CY CZ CQ	Aluminium	-	-	-	-	-	-	-	-	-	-	-	-	-	
			Steel	-	-	-	pag.1.54	pag.1.54	pag.1.54	pag.1.54	pag.1.54	pag.1.54	pag.1.54	pag.1.54	pag.1.54	pag.1.54	pag.1.54
			Stainless steel	-	-	-	-	-	-	-	-	-	-	-	-	-	-
	SQUARE JOINT ČTVERCOVÝ KLOUB ARTIC. A SQUADRA	CY CZ CQ	Aluminium	-	-	-	-	-	-	-	-	-	-	-	-	-	
			Steel	-	-	-	pag.1.55	pag.1.55	pag.1.55	pag.1.55	pag.1.55	pag.1.55	pag.1.55	pag.1.55	pag.1.55	pag.1.55	pag.1.55
			Stainless steel	-	-	-	pag.1.68	pag.1.68	pag.1.68	pag.1.68	pag.1.68	pag.1.68	pag.1.68	pag.1.68	pag.1.68	pag.1.68	pag.1.68
		Cyl.	Material	Ø8-10	Ø12-16	Ø20-25	Ø32	Ø40	Ø50	Ø63	Ø80	Ø100	Ø125	Ø160	Ø200	Ø250	
	SQUARE JOINT ARTIC. HEAD ČTVERCOVÝ KLOUB ARTIC. A SQUADRA SNODATA	CY CZ	Aluminium	-	-	-	-	-	-	-	-	-	-	-	-	-	
			Steel	-	-	-	pag.1.55	pag.1.55	pag.1.55	pag.1.55	pag.1.55	pag.1.55	pag.1.55	pag.1.55	pag.1.55	pag.1.55	pag.1.55
			Stainless steel	-	-	-	-	-	-	-	-	-	-	-	-	-	-
	INTERMEDIATE HINGE PŘEDBĚŽNÁ ZÁVĚS CERNIERA INTERMEDIA	CY	Aluminium	-	-	-	-	-	-	-	-	-	-	-	-	-	
			Steel	-	-	-	pag.1.56	pag.1.56	pag.1.56	pag.1.56	pag.1.56	pag.1.56	pag.1.56	pag.1.56	pag.1.56	pag.1.56	pag.1.56
			Stainless steel	-	-	-	-	-	-	-	-	-	-	-	-	-	-
	INTERMEDIATE HINGE STŘEDNÍ ZÁVĚS CERNIERA INTERMEDIA	CZ	Aluminium	-	-	-	-	-	-	-	-	-	-	-	-	-	
			Steel	-	-	-	pag.1.56	pag.1.56	pag.1.56	pag.1.56	pag.1.56	pag.1.56	pag.1.56	pag.1.56	pag.1.56	pag.1.56	pag.1.56
			Stainless steel	-	-	-	-	-	-	-	-	-	-	-	-	-	-
	INTERM. ADJUSTABLE HINGE STŘEDNÍ ZÁVĚS	CQ	Aluminium	-	-	-	-	-	-	-	-	-	-	-	-	-	
			Steel	-	-	-	-	-	-	-	-	-	-	-	-	-	-
			Stainless steel	-	-	-	-	-	-	-	-	-	-	-	-	pag.1.56	pag.1.56
	INTERM. HINGE THREAD STŘEDNÍ ZÁVĚS CERNIERA INTER. FILETTATA	CQ	Aluminium	-	-	-	-	-	-	-	-	-	-	-	-	-	
			Steel	-	-	-	-	-	-	-	-	-	-	-	-	-	-
			Stainless steel	-	-	-	-	-	-	-	-	-	-	-	-	pag.1.57	pag.1.57
	SUPPORT FOR INTER. HINGE LOŽISKO PRO STŘEDNÍ ZÁVĚS	CY CZ CQ	Aluminium	-	-	-	-	-	-	-	-	-	-	-	-	-	
			Steel	-	-	-	pag.1.57	pag.1.57	pag.1.57	pag.1.57	pag.1.57	pag.1.57	pag.1.57	pag.1.57	pag.1.57	pag.1.57	pag.1.57
			Stainless steel	-	-	-	-	-	-	-	-	-	-	-	-	-	-
	CENTERING RING FOR CM STŘEDÍCÍ KROUŽEK ANELLO DI CENTRAGGIO CM	CM	Aluminium	-	-	-	-	-	-	-	-	-	-	-	-	-	
			Steel	-	-	-	pag.1.57	pag.1.57	pag.1.57	pag.1.57	pag.1.57	pag.1.57	pag.1.57	pag.1.57	pag.1.57	pag.1.57	pag.1.57
			Stainless steel	-	-	-	-	-	-	-	-	-	-	-	-	-	-
	YOKE WITH CLIPS VIDLICE NA PÍSTNICI FORCELLA CON CLIPS	CY CZ	Aluminium	-	-	-	-	-	-	-	-	-	-	-	-	-	
			Steel	pag.1.11	pag.1.11	pag.1.11	pag.1.58	pag.1.58	pag.1.58	pag.1.58	pag.1.58	pag.1.58	pag.1.58	pag.1.58	pag.1.58	pag.1.58	pag.1.58
			Stainless steel	pag.1.17	pag.1.17	pag.1.17	pag.1.69	pag.1.69	pag.1.69	pag.1.69	pag.1.69	pag.1.69	pag.1.69	pag.1.69	pag.1.69	pag.1.69	pag.1.69

PEDESTAL
 BOČNÍ PATKA
 PIEDINO

Material: Steel
Materiál: Ocel
 Materiale: Acciaio

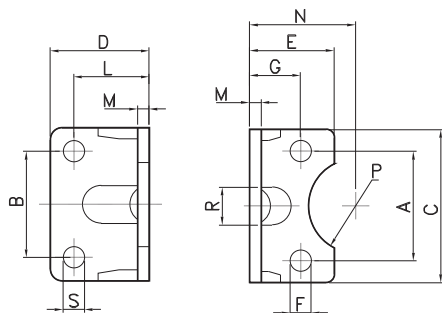
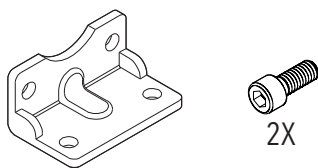

CODE	Ø
AR4152032-V	32
AR4152040-V	40
AR4152050-V	50
AR4152063-V	63
AR4152080-V	80
AR4152100-V	100
AR4152125-V	125
AR4152160-V	160
AR4152200-V	200
AR4152250-V	250

Ø	A	B	C	D	E	F	G	L	M	N	P	R	S	Peso (g)
32	32.5	32	45	35	30	7	15.75	24	4	32	15	11	7	66
40	38	36	52	36	30	7	17	28	4	36	17.5	15	9	78
50	46.5	45	65	47	36	9	21.75	32	5	45	20	16	9	168
63	56.5	50	75	45	35	9	21.75	32	5	50	22.5	18	9	190
80	72	63	95	55	47	11	27	41	6	63	22.5	17	12	382
100	89	75	115	57	53	11	26.5	41	6	71	27.5	24	14	452
125	110	90	140	70	70	14	35	45	8	90	30	-	16	1090
160	140	115	180	75	100	18	45	60	9	115	32.5	-	18	1188
200	175	135	220	100	100	18	47.5	70	12	135	37.5	-	22	3450
250	220	165	270	100	150	22	55	75	14	165	45	-	26	6600

FLANGE
 ČELNÍ (ZADNÍ) DESKA
 FLANGIA

Material: Steel
Materiál: Ocel
 Materiale: Acciaio

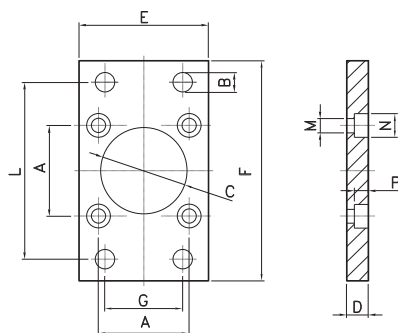
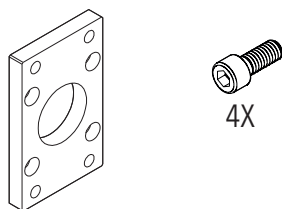

CODE	Ø
AR4151032-V	32
AR4151040-V	40
AR4151050-V	50
AR4151063-V	63
AR4151080-V	80
AR4151100-V	100
AR4151125-V	125
AR4151160-V	160
AR4151200-V	200
AR4151250-V	250

Ø	A	B	C	D	E	F	G	L	M	N	P	Peso (g)
32	32.5	7	30	10	45	80	32	64	6.5	10.5	6.5	190
40	38	9	35	10	52	90	36	72	6.5	10.5	6.5	246
50	46.5	9	40	12	65	110	45	90	8.5	13.5	8.5	478
63	56.5	9	45	12	75	120	50	100	8.5	13.5	8.5	622
80	72	12	45	16	95	150	63	126	10.5	16.5	10.5	1430
100	89	14	55	16	115	170	75	150	10.5	16.5	10.5	1986
125	110	16	60	20	140	205	90	180	13.5	20	12.5	3750
160	140	18	65	20	180	260	115	230	17	25	16.5	6350
200	175	22	75	25	220	300	135	270	17	25	16.5	11350
250	220	26	90	25	280	390	165	330	22.5	33	20	20100

MALE HINGE
 ZADNÍ KYVNÉ OKO
 CERNIERA MASCHIO

Material: Aluminium
Materiál: hliník
 Materiale: Alluminio

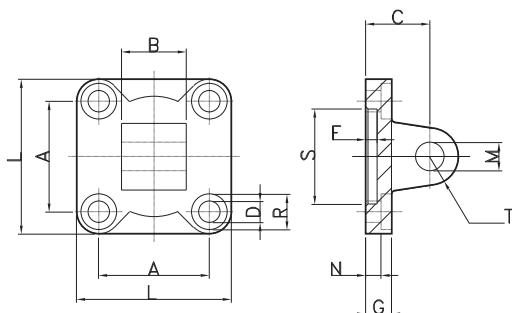
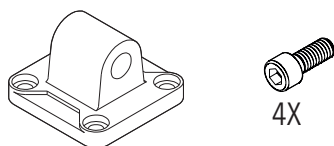

CODE	Ø
AR4149032-V	32
AR4149040-V	40
AR4149050-V	50
AR4149063-V	63
AR4149080-V	80
AR4149100-V	100
AR4149125-V	125
AR4149160-V	160
AR4149200-V	200
AR4149250-V	250

Ø	A	B	C	D	F	G	L	M	N	R	S	T	Peso (g)
32	32.5	26	22	6.6	5	9	45	10	5.5	11	30	10	54
40	38	28	25	6.6	5	9	52	12	5.5	11	35	12	76
50	46.5	32	27	9	5	11	65	12	6.5	15	40	12	124
63	56.5	40	32	9	5	11	75	16	6.5	15	45	16	212
80	72	50	36	11	5	14	95	16	10	18	45	16	420
100	89	60	41	11	5	14	115	20	10	18	55	20	666
125	110	70	50	14	7	20	140	25	10	20	60	25	1264
160	140	90	55	18	7	20	180	30	10	26	65	25	1846
200	175	90	60	18	7	25	220	30	11	26	75	25	2950
250	220	110	70	22	11	25	270	40	=	=	90	40	6200

MALE HINGE
 ZADNÍ KYVNÉ OKO
 CERNIERA MASCHIO

Material: Steel
 Materiál: Ocel
 Materiale: Acciaio

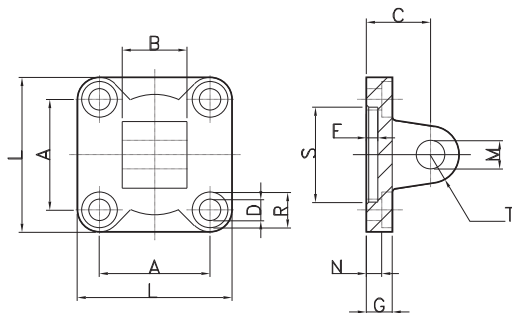
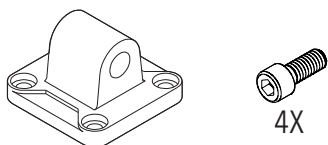

CODE	Ø
AR4186032-V	32
AR4186040-V	40
AR4186050-V	50
AR4186063-V	63
AR4186080-V	80
AR4186100-V	100
AR4186125-V	125
AR4186160-V	160
AR4186200-V	200
AR4186250-V	250

Ø	A	B	C	D	F	G	L	M	N	R	S	T	Peso (g)
32	32.5	26	22	6.6	5	9	45	10	5.5	11	30	10	54
40	38	28	25	6.6	5	9	52	12	5.5	11	35	12	76
50	46.5	32	27	9	5	11	65	12	6.5	15	40	12	124
63	56.5	40	32	9	5	11	75	16	6.5	15	45	16	212
80	72	50	36	11	5	14	95	16	10	18	45	16	420
100	89	60	41	11	5	14	115	20	10	18	55	20	666
125	110	70	50	14	7	20	140	25	10	20	60	25	1264
160	140	90	55	18	7	20	180	30	10	26	65	25	1846
200	175	90	60	18	7	25	220	30	11	26	75	25	2950
250	220	110	70	22	11	25	270	40	=	=	90	40	6200

FEMALE HINGE
 ZADNÍ KYVNÉ LOŽISKO
 CERNIERA FEMMINA

Material: Aluminium
 Materiál: hliník
 Materiale: Alluminio

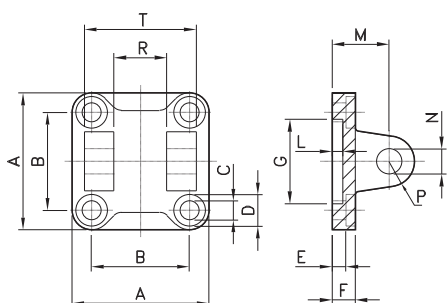
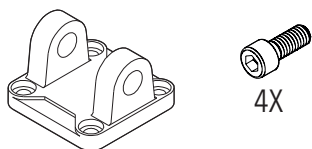

CODE	Ø
AR4147032-V	32
AR4147040-V	40
AR4147050-V	50
AR4147063-V	63
AR4147080-V	80
AR4147100-V	100
AR4147125-V	125
AR4147160-V	160
AR4147200-V	200
AR4147250-V	250

Ø	A	B	C	D	E	F	G	L	M	N	P	R	T	Peso (g)
32	45	32.5	6.6	11	5.5	9	30	5	22	10	10	26	45	48
40	52	38	6.6	11	5.5	9	35	5	25	12	12	28	52	75
50	65	46.5	9	15	6.5	11	40	5	27	12	12	32	60	124
63	75	56.5	9	15	6.5	11	45	5	32	16	16	40	70	192
80	95	72	11	18	10	14	45	5	36	16	16	50	90	380
100	115	89	11	18	10	14	55	5	41	20	20	60	110	620
125	140	110	14	20	10	20	60	7	50	25	25	70	130	1180
160	180	140	18	26	10	20	65	7	55	30	25	90	170	1780
200	220	175	18	26	11	25	75	7	60	30	25	90	170	2900
250	270	220	22	-	-	25	90	-	70	40	40	110	200	5800

FEMALE HINGE
 ZADNÍ KYVNÉ LOŽISKO
 CERNIERA FEMMINA

Material: Steel
 Materiál: Ocel
 Materiale: Acciaio

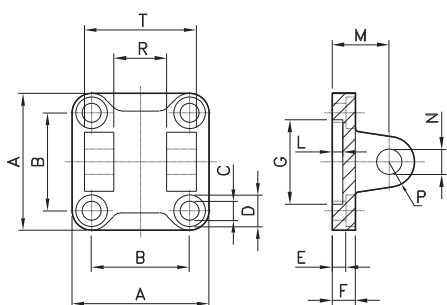
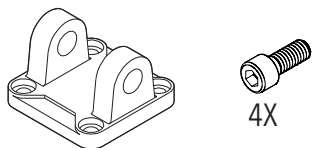

CODE	Ø
AR4184032-V	32
AR4184040-V	40
AR4184050-V	50
AR4184063-V	63
AR4184080-V	80
AR4184100-V	100
AR4184125-V	125
AR4184160-V	160
AR4184200-V	200
AR4184250-V	250

Ø	A	B	C	D	E	F	G	L	M	N	P	R	T	Peso (g)
32	45	32.5	6.6	11	5.5	9	30	5	22	10	10	26	45	48
40	52	38	6.6	11	5.5	9	35	5	25	12	12	28	52	75
50	65	46.5	9	15	6.5	11	40	5	27	12	12	32	60	124
63	75	56.5	9	15	6.5	11	45	5	32	16	16	40	70	192
80	95	72	11	18	10	14	45	5	36	16	16	50	90	380
100	115	89	11	18	10	14	55	5	41	20	20	60	110	620
125	140	110	14	20	10	20	60	7	50	25	25	70	130	1180
160	180	140	18	26	10	20	65	7	55	30	25	90	170	1780
200	220	175	18	26	11	25	75	7	60	30	25	90	170	2900
250	270	220	22	-	-	25	90	-	70	40	40	110	200	5800

PIVOT FOR FEMALE HINGE
ČEP
 PERNO PER CERNIERA FEMMINA

Material: Steel
Materiál: Ocel
 Materiale: Acciaio

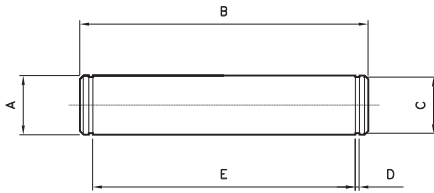
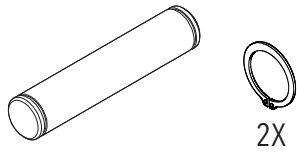

CODE	Ø
AR4150032	32
AR4150040	40
AR4150050	50
AR4150063	63
AR4150080	80
AR4150100	100
AR4150125	125
AR4150160	160
AR4150200	200
AR4150250	250

Ø	A	B	C	D	E	Peso (g)
32	10	53	9.6	1.1	46	32
40	12	60	11.5	1.1	53	52
50	12	68	11.5	1.1	61	60
63	16	78	15.2	1.1	71	122
80	16	98	15.2	1.1	91	152
100	20	118	19	1.3	111	290
125	25	139	23.9	1.3	132	530
160	30	178	28.6	1.6	171.5	978
200	30	178	28.6	1.6	171.5	978
250	40	211	37.5	1.85	202	2100

NARROW FEMALE HINGE
ZADNÍ KYVNÉ LOŽISKO
 CERNIERA FEMMINA STRETTA

Material: Aluminium
Materiál: hliník
 Materiale: Alluminio

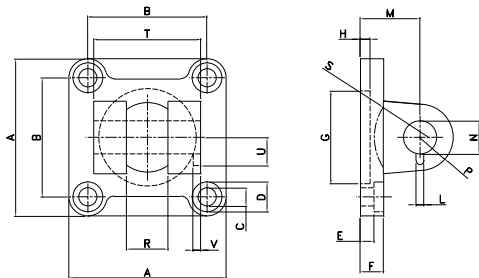
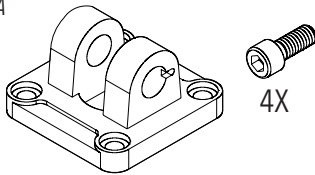

CODE	Ø
AR41801032-V	32
AR41801040-V	40
AR41801050-V	50
AR41801063-V	63
AR41801080-V	80
AR41801100-V	100
AR41801125-V	125
AR41801160-V	160
AR41801200-V	200

Ø	A	B	C	D	E	F	G	H	L	M	N	P	R	S	T	U
32	45	32.5	6.6	11	5.5	9	30	5	3.3	22	10	10	14	17	34	11.5
40	52	38	6.6	11	5.5	9	35	5	4.3	25	12	12	16	20	40	12
50	65	46.5	9	15	6.5	11	40	5	4.3	27	16	14	21	22	45	14
63	75	56.5	9	15	6.5	11	45	5	4.3	32	16	18	21	25	51	14
80	95	72	11	18	10	14	45	5	4.3	36	20	20	25	30	65	16
100	115	89	11	18	10	14	55	5	6.3	41	20	22	25	32	75	16
125	140	110	14	20	10	20	60	7	6.3	50	30	25	37	42	97	24
160	180	140	18	26	10	20	65	7	6.3	55	35	30	43	46	122	26.5
200	220	175	18	26	11	25	75	7	6.3	60	35	30	43	49	122	26.5

NARROW FEMALE HINGE
ZADNÍ KYVNÉ LOŽISKO
 CERNIERA FEMMINA STRETTA

Material: Steel
Materiál: Ocel
 Materiale: Acciaio

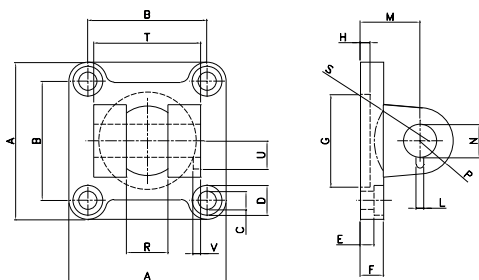
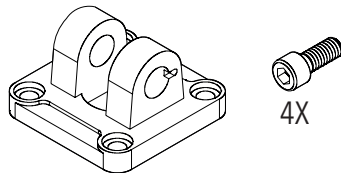

CODE	Ø
AR4212032-V	32
AR4212040-V	40
AR4212050-V	50
AR4212063-V	63
AR4212080-V	80
AR4212100-V	100
AR4212125-V	125

Ø	A	B	C	D	E	F	G	H	L	M	N	P	R	S	T	U
32	45	32.5	6.6	11	5.5	9	30	5	3.3	22	10	10	14	17	34	11.5
40	52	38	6.6	11	5.5	9	35	5	4.3	25	12	12	16	20	40	12
50	65	46.5	9	15	6.5	11	40	5	4.3	27	16	14	21	22	45	14
63	75	56.5	9	15	6.5	11	45	5	4.3	32	16	18	21	25	51	14
80	95	72	11	18	10	14	45	5	4.3	36	20	20	25	30	65	16
100	115	89	11	18	10	14	55	5	6.3	41	20	22	25	32	75	16
125	140	110	14	20	10	20	60	7	6.3	50	30	25	37	42	97	24

PIN ANTI-ROTATION FOR NARROW FEMALE HINGE
ČEP ANTIROTAČNÍ
 PERNO ANTIROTAZIONE PER CERNIERA STRETTA

Material: Steel
Materiál: Ocel
 Materiale: Acciaio

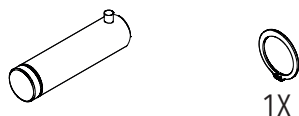

1X

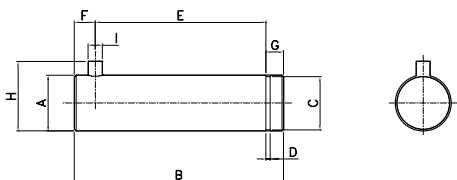

CODE	Ø
AR41803032	32
AR41803040	40
AR41803050	50
AR41803063	63
AR41803080	80
AR41803100	100
AR41803125	125
AR41803160	160
AR41803200	200

Ø	A	B	C	D	E	F	G	H	I	Peso (g)
32	10	41	9.6	1.1	32.5	4.5	4	14	3	26
40	12	48	11.5	1.1	38	6	4	16	4	42
50	16	54	15.2	1.1	43	6	5	20	4	84
63	16	60	15.2	1.1	49	6	5	20	4	94
80	20	75	19	1.3	63	6	6	24	4	184
100	20	85	19	1.3	73	6	6	24	4	208
125	30	110	28.6	1.6	94	9	7	36	6	606
160	35	135	33	1.6	119	9	7	41	6	972
200	35	135	33	1.6	119	9	7	41	6	972

MALE HINGE ART. HEAD
ZADNÍ KYVNÉ OKO
 CERNIERA MASCHIO SNODATA

Material: Aluminium
Materiál: hliník
 Materiale: Alluminio

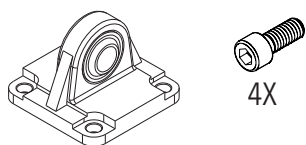

4X

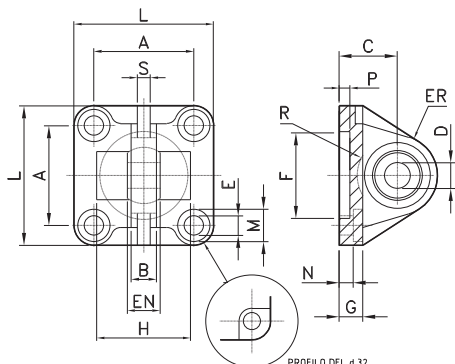

PROFILO DEL Ø 32

CODE	Ø
AR4226032-V	32
AR4226040-V	40
AR4226050-V	50
AR4226063-V	63
AR4226080-V	80
AR4226100-V	100
AR4226125-V	125
AR4226160-V	160
AR4226200-V	200
AR4226250-V	250

Ø	A ±0.2	B max	C JS15	D H7	EN -0.1	ER max	F H11	G	E H13	L	M H13	N ±0.2	P	H ±0.5	R ±0.5	Peso (g)
32	32.5	10.5	22	10	14	16	30	9	6.6	45	11	5.5	5	=	=	65
40	38	12	25	12	16	19	35	9	6.6	52	11	5.5	5	=	=	100
50	46.5	15	27	16	21	21	40	11	9	65	15	6.5	5	51	19	180
63	56.5	15	32	16	21	24	45	11	9	75	15	6.5	5	=	=	244
80	72	18	36	20	25	28.5	45	14	11	95	18	10	5	70	24	476
100	89	18	41	20	25	30	55	14	11	115	18	10	5	=	=	646
125	110	25	50	30	37	40	60	20	13.5	140	20	10	7	=	=	1410
160	140	28	55	35	43	45	65	20	18	180	26	10	7	=	=	
200	175	28	60	35	43	48	75	25	18	220	26	11	7	=	=	
250	220	33	70	40	49	52	90	25	22	270	33	11	11	=	=	

MALE HINGE ART. HEAD
ZADNÍ KYVNÉ OKO
 CERNIERA MASCHIO SNODATA

Material: Steel
Materiál: Ocel
 Materiale: Acciaio

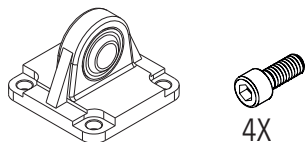

4X

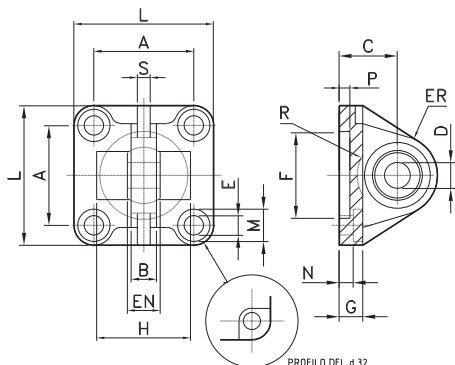

PROFILO DEL Ø 32

CODE	Ø
AR4261032-V	32
AR4261040-V	40
AR4261050-V	50
AR4261063-V	63
AR4261080-V	80
AR4261100-V	100
AR4261125-V	125

Ø	A ±0.2	B max	C JS15	D H7	EN -0.1	ER max	F H11	G	E H13	L	M H13	N ±0.2	P	H ±0.5	R ±0.5	Peso (g)
32	32.5	10.5	22	10	14	16	30	9	6.6	45	11	5.5	5	=	=	65
40	38	12	25	12	16	19	35	9	6.6	52	11	5.5	5	=	=	100
50	46.5	15	27	16	21	21	40	11	9	65	15	6.5	5	51	19	180
63	56.5	15	32	16	21	24	45	11	9	75	15	6.5	5	=	=	244
80	72	18	36	20	25	28.5	45	14	11	95	18	10	5	70	24	476
100	89	18	41	20	25	30	55	14	11	115	18	10	5	=	=	646
125	110	25	50	30	37	40	60	20	13.5	140	20	10	7	=	=	1410

SQUARE JOINT
ČTVERCOVÝ KLOUB
 ARTICOLAZIONE A SQUADRA

Material: Aluminium
Materiál: hliník
 Materiale: Alluminio

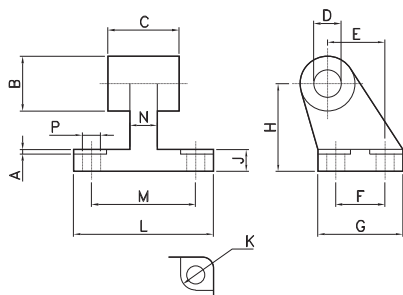
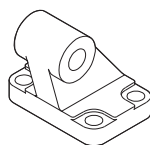

CODE	Ø
AR4156032	32
AR4156040	40
AR4156050	50
AR4156063	63
AR4156080	80
AR4156100	100
AR4156125	125
AR4156160	160
AR4156200	200
AR4156250	250

Ø	A	B	C	D	E	F	G	H	J	K	L	M	N	P	Peso (g)
32	1.6	20	26	10	21	18	31	32	8	11	51	38	10	6.6	56
40	1.6	22	28	12	24	22	35	36	10	11	54	41	15	6.6	80
50	1.6	26	32	12	33	30	45	45	12	15	65	50	16	9	142
63	1.6	30	40	16	37	35	50	50	14	15	67	52	16	9	200
80	2.5	30	50	16	47	40	60	63	14	18	86	66	20	11	312
100	2.5	38	60	20	55	50	70	71	17	18	96	76	20	11	510
125	3.2	45	70	25	70	60	90	90	20	20	124	94	30	14	826
160	4	63	90	30	97	88	126	115	25	20	156	118	36	14	
200	4	63	90	30	105	90	130	135	30	26	162	122	40	18	
250	4.5	80	110	40	128	110	160	165	35	33	200	150	45	22	

SQUARE JOINT
ČTVERCOVÝ KLOUB
 ARTICOLAZIONE A SQUADRA

Material: Steel
Materiál: Ocel
 Materiale: Acciaio

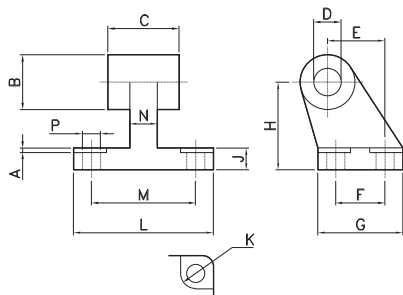
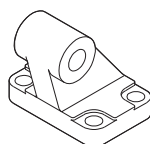

CODE	Ø
AR4207032	32
AR4207040	40
AR4207050	50
AR4207063	63
AR4207080	80
AR4207100	100
AR4207125	125

Ø	A	B	C	D	E	F	G	H	J	K	L	M	N	P	Peso (g)
32	1.6	20	26	10	21	18	31	32	8	11	51	38	10	6.6	56
40	1.6	22	28	12	24	22	35	36	10	11	54	41	15	6.6	80
50	1.6	26	32	12	33	30	45	45	12	15	65	50	16	9	142
63	1.6	30	40	16	37	35	50	50	14	15	67	52	16	9	200
80	2.5	30	50	16	47	40	60	63	14	18	86	66	20	11	312
100	2.5	38	60	20	55	50	70	71	17	18	96	76	20	11	510
125	3.2	45	70	25	70	60	90	90	20	20	124	94	30	14	826

SQUARE JOINT ARTIC. HEAD
ČTVERCOVÝ KLOUB
 ARTIC. A SQUADRA SNODATA

Material: Steel
Materiál: Ocel
 Materiale: Acciaio

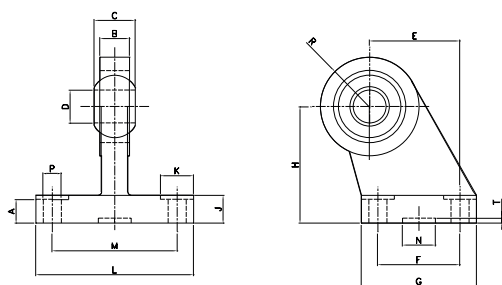
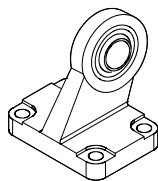

CODE	Ø
AR4208032	32
AR4208040	40
AR4208050	50
AR4208063	63
AR4208080	80
AR4208100	100
AR4208125	125

Ø	A	B	C	D	E	F	G	H	J	K	L	M	N	P	R	T	Peso (g)
32	8.5	10.5	14	10	21	18	31	32	10	11	51	38	20	6.6	15	3	178
40	8.5	12	16	12	24	22	35	36	10	11	54	41	20	6.6	18	3	268
50	10.5	15	21	16	33	30	45	45	12	15	65	50	20	9	20	3	459
63	10.5	15	21	16	37	35	50	50	12	15	67	52	20	9	23	3	550
80	11.5	18	25	20	47	40	60	63	14	18	86	66	20	11	27	3	970
100	12.5	18	25	20	55	50	70	71	15	18	96	76	20	11	30	3	1326
125	17	25	37	30	70	60	90	90	20	20	124	94	20	13.5	40	3	3000

INTERMEDIATE HINGE FOR CY
PŘEDBĚŽNÁ ZÁVĚRKA PRO CY
 CERNIERA INTERMEDIA PER CY

Material: Aluminium
Materiál: hliník
 Materiale: Alluminio

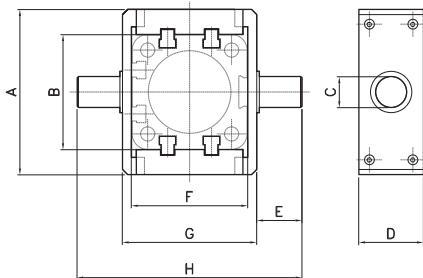
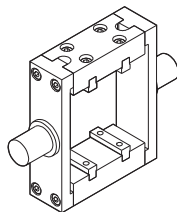

CODE	Ø
AR4158032	32
AR4158040	40
AR4158050	50
AR4158063	63
AR4158080	80
AR4158100	100
AR4158125	125

Ø	A	B	C	D	E	F	G	H
32	65	44.6	12	25	17.5	45	52	87
40	74.8	50.8	16	25	21.5	50.8	62	105
50	90.3	60.3	16	25	21.5	60.6	74	117
63	94.5	70.5	20	30	23.5	70	91	138
80	109.3	87.5	20	30	23.5	87.2	111	158
100	134	106.6	25	40	33	106.2	129	195
125	160	132.6	25	40	33	132.1	156.7	222.7

INTERMEDIATE HINGE FOR CZ
PŘEDBĚŽNÁ ZÁVĚRKA PRO CZ
 CERNIERA INTERMEDIA PER CZ

Material: Steel
Materiál: Ocel
 Materiale: Acciaio

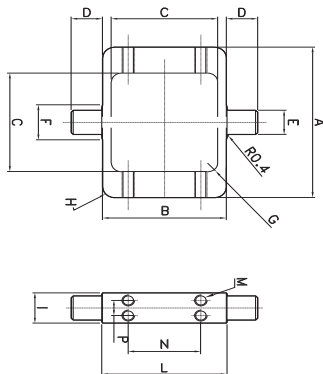
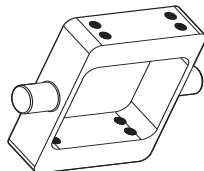

CODE	Ø
AR4279032	32
AR4279040	40
AR4279050	50
AR4279063	63
AR4279080	80
AR4279100	100
AR4279125	125

Ø	A	B	C	D	E	F	G	H	I	L	M	N	P	Peso (g)
32	70	50	45	12	12	-	5	4	18	50	M5	32.5	7	250
40	78	62	51	16	16	20	5	5	20	63	M5	38	8	410
50	91	74	60.8	16	16	20	6	6	20	75	M6	46.5	8	530
63	94	88	70.5	20	20	25	6	6	25	90	M6	56.5	12	775
80	130	109	87.5	20	20	25	7	7	25	110	M8	72	12	1430
100	145	130	107	25	25	30	8	8	30	132	M8	89	15	1950
125	154	155	133	25	25	32	11	11	32	160	M10	110	15	1600

INTERMEDIATE ADJUSTABLE HINGE
STŘEDNÍ ZÁVĚS
 CERNIERA INTERMEDIA REGOLABILE

Material: Steel
Materiál: Ocel
 Materiale: Acciaio

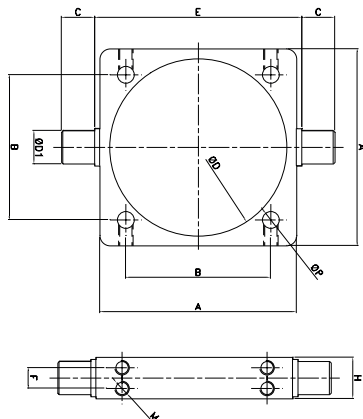
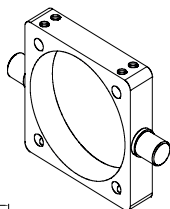

CODE	Ø
AR4182160	160
AR4182200	200

Ø	A	B	C	D	D1	E	F	H	M	P	Peso (g)
160	190	140	32	171	32	200	18	40	M12	16.25	4150
200	240	175	32	211	32	250	18	40	M12	16.25	7300

INTERMEDIATE HINGE THREAD
STŘEDNÍ ZÁVĚS
 CERNIERA INTERMEDIA ROTONDA FILETTATA

Material: Steel
Materiál: Ocel
 Materiale: Acciaio

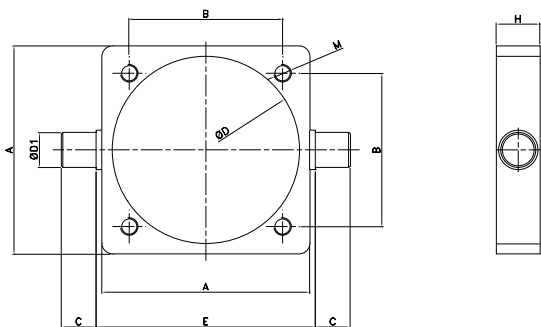
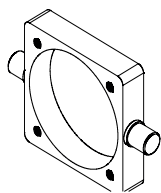

CODE	Ø
AR4183160	160
AR4183200	200
AR4183250	250

Ø	A	B	C	D	D1	E	H	M	Peso (g)
160	190	140	32	171	32	200	40	M16	4300
200	240	175	32	211	32	250	40	M16	7450
250	296	220	40	268	40	320	50	M20	13000

SUPPORT FOR INTERMEDIATE HINGE
LOŽISKO PRO STŘEDNÍ ZÁVĚS
 SUPPORTO PER CERNIERA INTERMEDIA

Material: Steel
Materiál: Ocel
 Materiale: Acciaio

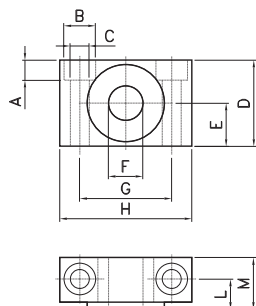
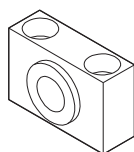

CODE	Ø
AR4159032	32
AR4159040	40-50
AR4159063	63-80
AR4159100	100-125
AR4159160	160-200
AR4159250	250

Ø	A	B	C	D	E	F	G	H	L	M	Peso (g)
32	7	11	6.6	30	15	12	32	46	10.5	18	100
40-50	9	15	9	36	18	16	36	55	12	21	150
63-80	11	18	11	40	20	20	42	65	13	23	234
100-125	13	20	14	50	25	25	50	75	16	28.5	435
160-200	17	26	18	60	30	32	60	92	22.5	40	
250	20	33	22	70	35	40	90	140	31	56	

CENTERING RING FOR CM - ISO 21287
STŘEDNÍ KROUŽEK PRO CM - ISO 21287
 ANELLO DI CENTRAGGIO PER CM - ISO 21287

Material: Aluminium
Materiál: hliník
 Materiale: Alluminio

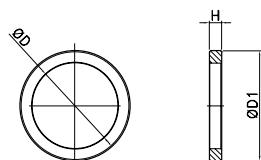
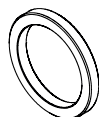

CODE	Ø
AR43977032	32
AR43977040	40
AR43977050	50
AR43977063	63
AR43977080	80
AR43977100	100

Ø	D	D1	H
32	20.5	30	4
40	25.5	35	4
50	30.5	40	5
63	35	45	5
80	35	45	6
100	45	55	6

YOKE WITH CLIP
 VIDLICE NA PÍSTNICI
 FORCELLA CON CLIP

Material: Steel
 Materiál: Ocel
 Materiale: Acciaio

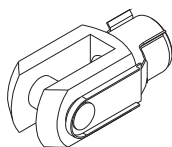

CODE	Ø
AR40673	32
AR40674	40
AR40675	50-63
AR40676	80-100

Ø	A	B	C	D	E	F	G	H	I	M	L	L1	L2	L3
32	20	10	20	10	52	40	18	23	15	M10x1.25	26	10	39	46
40	24	12	24	12	62	48	20	28	18	M12x1.25	32	12	47	55
50-63	32	16	32	16	83	64	26	36	24	M16x1.5	40	14	62	72
80-100	40	20	40	20	105	80	34	44	30	M20x1.5	48	16	72	88

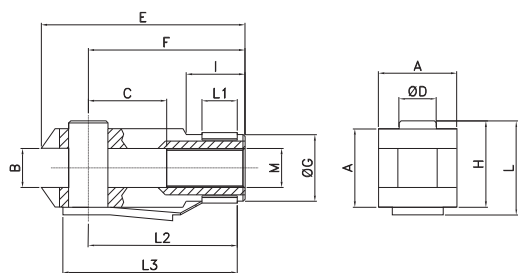

YOKE WITH CLIPS
 VIDLICE NA PÍSTNICI
 FORCELLA CON PERNO

Material: Steel
 Materiál: Ocel
 Materiale: Acciaio

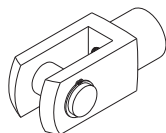

CODE	Ø
AR40678	125
AR40679	160-200
AR4272250	250

Ø	A	B	C	D	E	F	G	M	L	L1
125	55	30	54	30	148	110	48	M27x2	65	38
160/200	70	35	72	35	188	144	60	M36x2	84	40
250	85	40	84	40	232	168	70	M42x2	104.3	63.5

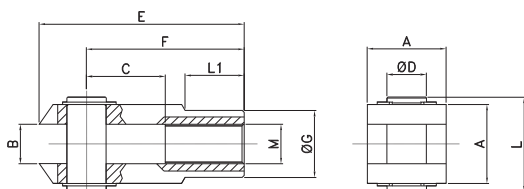

ROD ENDS
 OKO KYVNÉ
 TESTA A SNODO

Material: Steel
 Materiál: Ocel
 Materiale: Acciaio



CODE	Ø
AR40660	32
AR40662	40
AR40665	50-63
AR40666	80-100
AR40667	125
AR40669	160-200
AR40668	250

Ø	A	B	C	D	E	F	G	H	J	L	M	N	O	P
32	17	14	10.5	M10x1.25	15	19	6.5	15	43	57	10	12.9	20	28
40	19	16	12	M12x1.25	17.5	22	6.5	17	50	66	12	15.4	22	32
50-63	22	21	15	M16x1.5	22	27	8	23	64	85	16	19.3	28	42
80-100	30	25	18	M20x1.5	27.5	34	10	27	77	102	20	24.3	33	50
125	41	37	25	M27x2	40	50	15	36	110	145	30	34.8	51	70
160-200	50	43	28	M36x2	46	58	17	41	125	165	35	37.7	56	80
250	55	49	33	M42x2	53	65	19	45	142	187.5	40	45.2	60	91

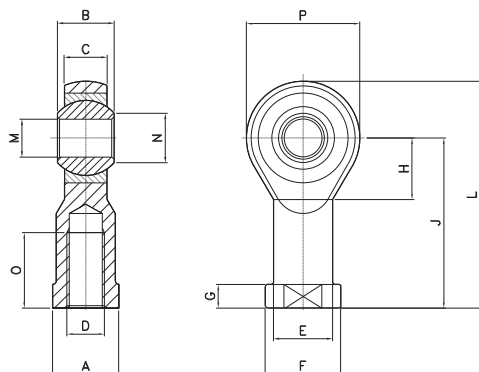

SELF-ALIGNING JOINT
FLEXO SPOJKA
 GIUNTO AUTOALLINEANTE

Material: Steel
Materiál: Ocel
 Materiale: Acciaio

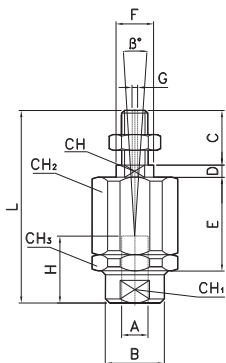
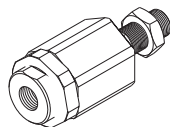

CODE	Ø
AR40689	32
AR40691	40
AR40693	50-63
AR40694	80-100

Ø	A	B	C	D	E	F	G	H	L	CH	CH ₁	CH ₂	CH ₃	B°
32	M10x1.25	22	20	5	35	14	2	20	71	12	19	30	32	10
40	M12x1.25	22	24	5	35	14	2	20	75	12	19	30	32	10
50-63	M16x1.5	32	32	8	54	22	2	32	103	20	30	41	45	10
80-100	M20x1.5	32	40	8	54	22	2	40	119	20	30	41	45	10

FLOATING JOINT
PŘÍRUBA NA PÍSTNICI
 GIUNTO FLOTTANTE

Material: Steel
Materiál: Ocel
 Materiale: Acciaio

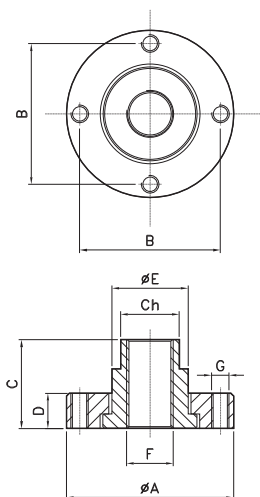
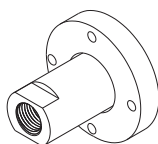

CODE	Ø
KU0017016	16
KU0017020	20
KU0017025	25
KU0017032	32
KU0017040	40
KU0017050	50-63
KU0017080	80-100

Ø	ØA	B	C	D	ØE	F	G	CH
16	28.5	22.5	15	6	11	M5	M5	8
20	31.5	25.5	18	7.5	14	M8	M5	12
25	31.5	25.5	18	7.5	14	M10	M5	12
32	38	31	19	11	17	M10	M5	15
40	38	31	19	11	17	M12	M5	15
50-63	57	48	27	12	26	M16	M6	20
80-100	63	54	27	12	32	M20	M6	26

NUT FOR ROD
MATICE NA PÍSTNICI
 DADO PER STELO

Material: Steel
Materiál: Ocel
 Materiale: Acciaio

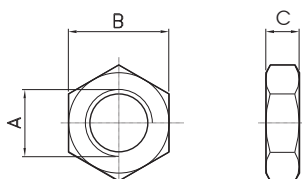

CODE	Ø	A	B	C
DAD10X1.25	32	M10X1.25	17	8
DAD12X1.25	40	M12X1.25	19	6
DAD16X1.5	50-63	M16X1.5	22	6
DAD20X1.5	80-100	M20X1.5	30	8
DAD27X2	125	M27X2	41	12
DAD36X2	160-200	M36X2	55	18

VALVE FIXING PLAQUE FOR CYLINDERS
PLAVIDLO PRO UPEVNĚNÍ VENTILU PRO CYLINDRY
 PIATRINA FISSAGGIO VALVOLA SU CILINDRO CY

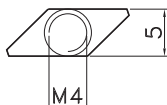
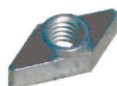

CODE

AR4213 without screws / **bez šroubů** / senza viti
 AR4213V with screws for VY / **se šrouby pro VY** / con viti per VY

OVAL SWITCH
MAGNETICKÝ SNÍMAČ POLOHY
 SENSORE OVALE

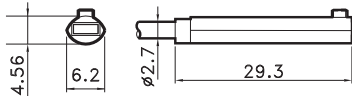

CODE

AR4019010 REED (MT.2,5) / **REED (MT.2,5)** / REED (MT.2,5)
 AR4019020 HALL (MT.2,5) / **HALL (MT.2,5)** / HALL (MT.2,5)
 AR4019110 REED + M8 (CM 30) / **REED + M8** / REED + M8 (CM 30)
 AR4019120 HALL + M8 (CM 30) / **HALL + M8** / HALL + M8 (CM 30)

For technical data see page 1.61
Technické údaje viz strana 1.61
 Per i dati tecnici vedere pag. 1.61

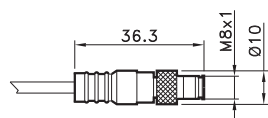

4= black / **Černá** / nero
 1= brown / **hnědý** / hnědýe
 3= blue / **modrý** / azzurro

T SWITCH
MAGNETICKÝ SNÍMAČ POLOHY
 SENSORE A T

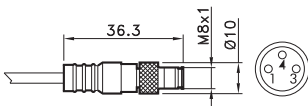
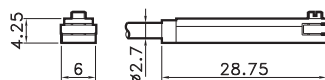

4= black / **Černá** / nero
 1= brown / **hnědý** / hnědýe
 3= blue / **modrý** / azzurro

CODE

AR4023010 REED (MT.2,5) / **REED (MT.2,5)** / REED (MT.2,5)
 AR4023020 HALL (MT.2,5) / **HALL (MT.2,5)** / HALL (MT.2,5)
 AR4023110 REED + M8 (CM 30) / **REED + M8** / REED + M8 (CM 30)
 AR4023120 HALL + M8 (CM 30) / **HALL + M8** / HALL + M8 (CM 30)

For technical data see page 1.62
Technické údaje viz strana 1.62
 Per i dati tecnici vedere pag. 1.62

EXTENSION CABLE 2,5 mt
PRODLUŽOVACÍ KABEL 2,5 mt
 PROLUNGA CAVO 2,5 mt

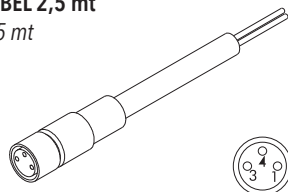

4= black / **Černá** / nero
 1= brown / **hnědý** / hnědýe
 3= blue / **modrý** / azzurro

CODE

AR4300 WITH M8 2 WIRES / **S VODIČI M8 2** / CON M8 2 FILI
 AR4301 WITH M8 3 WIRES / **S VODIČI M8 3** / CON M8 3 FILI

ADAPTOR FOR 'T' SWITCH FOR CQ CYLINDERS
ADAPTÉR PŘEPÍNAČE „T“ PRO CYLINDRY CQ
 ADATTATORE SENSORE A 'T' PER CILINDRO SERIE CQ

Material: Aluminium
Materiál: hliník
 Materiale: Alluminio

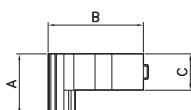
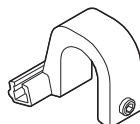
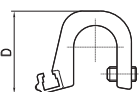

CODE

AR420080 160-200
 AR4200125 250

Ø	A	B	C	D
160-200	25	38	15	30
250	25	40	15	35