

Přímé škrtící ventily / Direct Choking Valves

Typ RFU, RFB / RFU, RFB Type

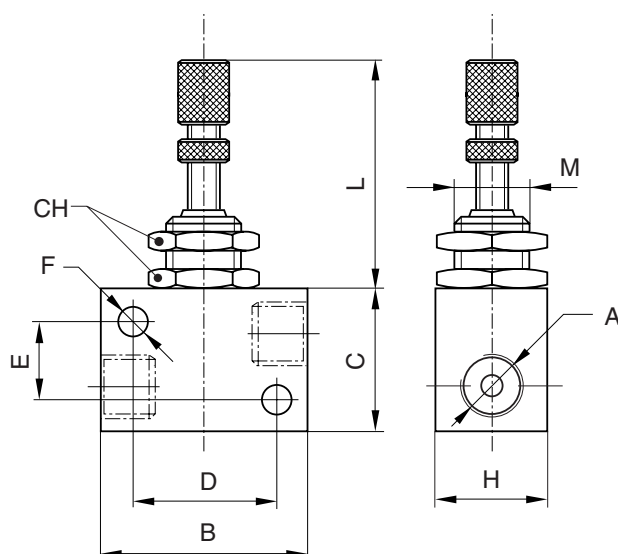

Použití Use	slouží pro řízení rychlosti pohybu pneumatických válců škrcením průtoku vzduchu Serve to control speed of motion of pneumatic cylinders by choking the air flow
Konstrukce ventilů Construction of valves	přímý škrtící ventil v provedení s možností montáže do panelu nebo do potrubí se škrcením v jednom nebo v obou směrech Direct choking valve in a type with option of panel built-in or pipe built-in assembly with choking in one or both directions
Konstrukční materiály Construction material	mosaz OT 58 UNI 5705 (CuZn40Pb2), nerez ocel, hliník 11S, NBR 70 OT 58 UNI 5705 brass (CuZn40Pb2), stainless steel, 11S aluminum, NBR 70
Pracovní poloha Working position	libovolná, s možností montáže do panelu Any, with option of mounting into panel
Pracovní rozsah tlaku Working pressure range	0,1 ÷ 1 MPa 0,1 ÷ 1 MPa
Rozsah teplot Temperature range	0°C ÷ +60°C 0°C ÷ +60°C
Pracovní médium Working medium	stlačený vzduch tř. 5 dle ČSN ISO 8573-1 Compressed air Class 5 according to ČSN ISO 8573-1



Schematická značka Schematic symbol	Typ Type	Obj. číslo Order No.	Max. průtok Q_{max} Max. flow Q_{max} $Ndm^3 \cdot min^{-1}$	A	B	C	H	D	E	F	L	M	CH	Hmotnost kg Weight in kg
	RFU M5	A12.047.4	60	M5	26	16	12	18	8	4,5	35	M10x0,75	12	0,02
	RFU 1/8	A12.000.4	120	G1/8"	32	22	17	23	13	4,5	35	M12x0,75	15	0,035
	RFU 1/4	A12.001.4	300	G1/4"	40	32	22	30	22	4,5	35	M12x0,75	15	0,130
	RFU 3/8	A12.002.4	600	G3/8"	56	42	27	43	27	6,5	43	M18x1,00	24	0,225
	RFU 1/2	A12.003.4	600	G1/2"	56	42	27	43	27	6,5	43	M18x1,00	24	0,225
	RFB M5	A12.049.4	60	M5	26	16	12	18	8	4,5	35	M10x0,75	12	0,02
	RFB 1/8	A12.006.4	210	G1/8"	32	22	17	23	13	4,5	35	M12x0,75	15	0,035
	RFB 1/4	A12.007.4	300	G1/4"	40	32	22	30	22	4,5	35	M12x0,75	15	0,130
	RFB 3/8	A12.008.4	500	G3/8"	56	42	27	43	27	6,5	43	M18x1,00	24	0,225
	RFB 1/2	A12.009.4	500	G1/2"	56	42	27	43	27	6,5	43	M18x1,00	24	0,225

Úhlové škrticí ventily – nástrčné provedení

Angle Choking Valves – Socket Type

Typ SZUVS / Type SZUVS



Použití Use	slouží pro řízení rychlosti pohybu pneumatických válců škrcením průtoku vzduchu Serve to control speed of motion of pneumatic cylinders by choking the air flow
Konstrukce ventilů Construction of valves	úhlový škrticí ventil v nástrčném provedení se škrcením při odvodušňování, venting, or in both directions
Konstrukční materiály Construction material	mosaz OT 58 UNI 5705 (CuZn40Pb2) galvanicky poniklována, polyacetalová pryskyřice, nerez ocel, NBR 70 OT 58 UNI 5705 brass (CuZn40Pb2), nickel plated, polyacetal resin, stainless steel, NBR 70
Pracovní poloha Working position	libovolná, s možností montáže přímo na pneuválec Any, with option of mounting directly on a pneumatic cylinder
Pracovní rozsah tlaku Working pressure range	0,1 ÷ 1 MPa 0,1 ÷ 1 MPa
Rozsah teplot Temperature range	0°C ÷ +80°C 0°C ÷ +80°C
Pracovní médium Working medium	stlačený vzduch tř. 5 dle ČSN ISO 8573-1 Compressed air Class 5 according to ČSN ISO 8573-1
Doporučené hadice Recommended hoses	plastové hadičky PE, PA, PTFE s vnějšími rozměry 4, 6, 8 mm (i nekalibrované) PE, PA, PTFE plastic hoses with external dimensions of 4, 6, 8 mm (also non-calibrated)



SZS ... C

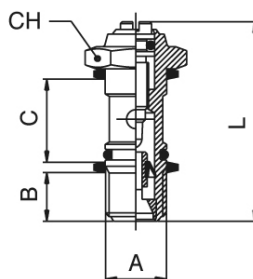

Schematická značka Schematic symbol	Typ Type	Obj. číslo Order No.	A	B	C	L	CH
	SZS M5C	BU 8900 M5	M5	4	12,5	24	8
	SZS 18C	BU 8900 G18	1/8	5,5	15	30,5	4
	SZS 14C	BU 8900 G14	1/4	8,5	17	35,5	7
	SZS 38C	BU 8900 G38	3/8	9	20	41	20
	SZS 12C	BU 8900 G12	1/2	10	24	47	24

SZR ... C

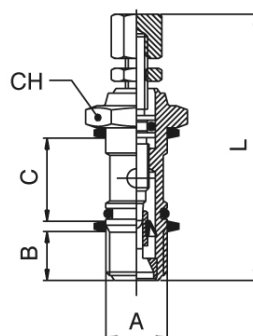

Schematická značka Schematic symbol	Typ Type	Obj. číslo Order No.	A	B	C	Lmin	Lmax	CH
	SZR M5C	BU 8905 M5	M5	4	12,5	33	37,5	8
	SZR 18C	BU 8905 G18	1/8	5,5	15	41	46,5	14
	SZR 14C	BU 8905 G14	1/4	8,5	17	46,5	52,5	17
	SZR 38C	BU 8905 G38	3/8	9	20	56,5	63,5	20
	SZR 12C	BU 8905 G12	1/2	10	24	62	69,5	24

Úhlové škrticí ventily / Angle Choking Valves

Typ SZS, SZR / Type SZS, SZR



SZS ... V

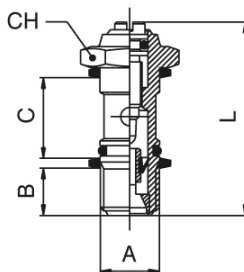

Schematická značka Schematic symbol	Typ Type	Obj. číslo Order No.	A	B	C	L	CH
	SZS M5V	BU 8910 M5	M5	4	12,5	24	8
	SZS 18V	BU 8910 G18	1/8	5,5	15	30,5	4
	SZS 14V	BU 8910 G14	1/4	8,5	17	35,5	7
	SZS 38V	BU 8910 G38	3/8	9	20	41	20
	SZS 12V	BU 8910 G12	1/2	10	24	47	24

SZR ... V

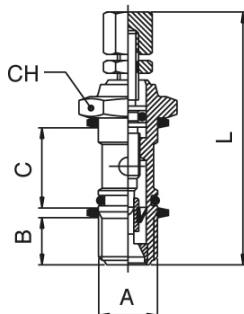

Schematická značka Schematic symbol	Typ Type	Obj. číslo Order No.	A	B	C	Lmin	Lmax	CH
	SZR M5V	BU 8915 M5	M5	4	12,5	33	37,5	8
	SZR 18V	BU 8915 G18	1/8	5,5	15	41	46,5	14
	SZR 14V	BU 8915 G14	1/4	8,5	17	46,5	52,5	17
	SZR 38V	BU 8915 G38	3/8	9	20	56,5	63,5	20
	SZR 12V	BU 8915 G12	1/2	10	24	62	69,5	24

SZS ... B

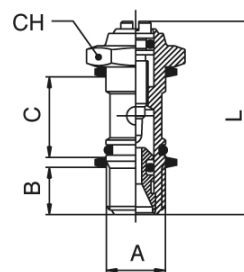

Schematická značka Schematic symbol	Typ Type	Obj. číslo Order No.	A	B	C	L	CH
	SZS M5B	BU 8920 M5	M5	4	12,5	24	8
	SZS 18B	BU 8920 G18	1/8	5,5	15	30,5	4
	SZS 14B	BU 8920 G14	1/4	8,5	17	35,5	7
	SZS 38B	BU 8920 G38	3/8	9	20	41	20
	SZS 12B	BU 8920 G12	1/2	10	24	47	24

Úhlové škrticí ventily / Angle Choking Valves

Typ SZS, SZR / Type SZS, SZR



SZR ... B

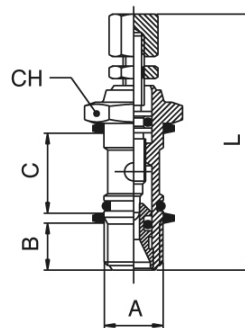

Schematická značka Schematic symbol	Typ Type	Obj. číslo Order No.	A	B	C	Lmin	Lmax	CH
	SZR M5B	BU 8925 M5	M5	4	12,5	33	37,5	8
	SZR 18B	BU 8925 G18	1/8	5,5	15	41	46,5	14
	SZR 14B	BU 8925 G14	1/4	8,5	17	46,5	52,5	17
	SZR 38B	BU 8925 G38	3/8	9	20	56,5	63,5	20
	SZR 12B	BU 8925 G12	1/2	10	24	62	69,5	24

Kruhové objímky Banjo body



Jednoduchá kruhová objímka k dutému šroubu typ H Single banjo body

Typ Typ	Objednací č. Order No.	Hadička Hose	A	D	S	L	
RE-54B	BU 1500 M54	4/2,7	M5	5,1	9	12,5	21,5
RE-184B	BU 1500 G184	4/2,7	1/8	10	14	15	23,3
RE-55B	BU 1500 M55	5/3	M5	5,1	9	12,5	21,5
RE-185B	BU 1500 G185	5/3	1/8	10	14	15	23,3
RE-56B	BU 1500 M56	6/4	M5	5,1	9	12,5	21,5
RE-186B	BU 1500 G186	6/4	1/8	10	14	15	23,3
RE-146B	BU 1500 G146	6/4	1/4	13,3	18	17	25,3
RE-386B	BU 1500 G386	6/4	3/8	16,7	21	20	26,8
RE-188B	BU 1500 G188	8/6	1/8	10	14	15	24,7
RE-148B	BU 1500 G148	8/6	1/4	13,3	18	17	27,6
RE-388B	BU 1500 G388	8/6	3/8	16,7	21	20	27,7
RE-128B	BU 1500 G128	8/6	1/2	21	26	24	31,2
RE-1810B	BU 1500 G1810	10/8	1/8	10	14	15	27,5
RE-1410B	BU 1500 G1410	10/8	1/4	13,3	18	17	29,5
RE-3810B	BU 1500 G3810	10/8	3/8	16,7	21	20	30,5
RE-1210B	BU 1500 G1210	10/8	1/2	21	26	24	34
RE-3812B	BU 1500 G3812	12/10	3/8	16,7	21	20	31,5
RE-1212B	BU 1500 G1212	12/10	1/2	21	26	24	35
RE-1215B	BU 1500 G1215	15/12,5	1/2	21	26	24	36,5

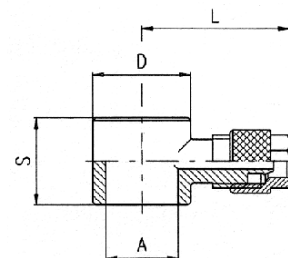

Dvojitá kruhová objímka k dutému šroubu typ H Double banjo body

Typ Type	Objednací č. Order No.	Hadička Hose		A	D	S	L
RD-54B	BU 1510 M54	4/2,7	M5	5,1	9	12,5	43
RD-184B	BU 1510 G184	4/2,7	1/8	10	14	15	46,6
RD-55B	BU 1510 M55	5/3	M5	5,1	9	12,5	43
RD-185B	BU 1510 G185	5/3	1/8	10	14	15	46,6
RD-56B	BU 1510 M56	6/4	M5	5,1	9	12,5	43
RD-186B	BU 1510 G186	6/4	1/8	10	14	15	46,6
RD-146B	BU 1510 G146	6/4	1/4	13,3	18	17	50,6
RD-386B	BU 1510 G386	6/4	3/8	16,7	21	20	53,6
RD-188B	BU 1510 G188	8/6	1/8	10	14	15	49,4
RD-148B	BU 1510 G148	8/6	1/4	13,3	18	17	55,2
RD-388B	BU 1510 G388	8/6	3/8	16,7	21	20	55,4
RD-128B	BU 1510 G128	8/6	1/2	21	26	24	61
RD-1810B	BU 1510 G1810	10/8	1/8	10	14	15	55
RD-1410B	BU 1510 G1410	10/8	1/4	13,3	18	17	59
RD-3810B	BU 1510 G3810	10/8	3/8	16,7	21	20	61
RD-1210B	BU 1510 G1210	10/8	1/2	21	26	24	68
RD-3812B	BU 1510 G3812	12/10	3/8	16,7	21	20	63
RD-1212B	BU 1510 G1212	12/10	1/2	21	26	24	70
RD-1215B	BU 1510 G1215	15/12,5	1/2	21	26	24	73

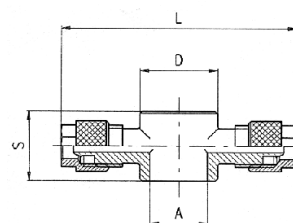
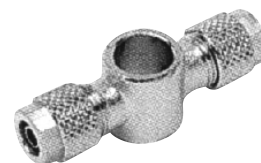

Jednoduchá kruhová objímka k dutému šroubu typ H Single banjo body

Typ Type	Objednací č. Order No.	Hadička Hose	A	B	L	CH	Použití s dutým šroubem typ Using hollow screw type	
RES-54B	BU 50500	M54	4	M5	12,5	19	-	H-x 5B
RES-184B	BU 50500	G184	4	1/8	15	21	14	H-x 18B
RES-55B	BU 50500	M55	5	M5	12,5	20	-	H-x 5B
RES-185B	BU 50500	G185	5	1/8	15	21,5	14	H-x 18B
RES-145B	BU 50500	G145	5	1/4	17	24,5	18	H-x 14B
RES-56B	BU 50500	M56	6	M5	12,5	20,5	-	H-x 5B
RES-186B	BU 50500	G186	6	1/8	15	22	14	H-x 18B
RES-146B	BU 50500	G146	6	1/4	17	25	18	H-x 14B
RES-188B	BU 50500	G188	8	1/8	15	24	14	H-x 18B
RES-148B	BU 50500	G148	8	1/4	17	26	18	H-x 14B
RES-388B	BU 50500	G388	8	3/8	20	28	21	H-x 38B
RES-1410B	BU 50500	G1410	10	1/4	17	29	18	H-x 14B
RES-3810B	BU 50500	G3810	10	3/8	20	30,5	21	H-x 38B
RES-3812B	BU 50500	G3812	12	3/8	20	32,5	21	H-x 38B
RES-1214B	BU 50500	G1214	14	1/2	24	35,5	25	H-x 15B

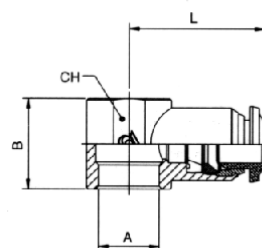

Dvojitá kruhová objímka k dutému šroubu typ H Double banjo body

Typ Type	Objednací č. Order No.	Hadička Hose	A	B	L	CH	Použití s dutým šroubem typ Using hollow screw type	
RDS-54B	BU 50510	M54	4	M5	12,5	38	-	H-x5B
RDS-184B	BU 50510	G184	4	1/8	15	42	14	H-x18B
RDS-185B	BU 50510	G185	5	1/8	15	43	14	H-x18B
RDS-145B	BU 50510	G145	5	1/4	17	49	18	H-x14B
RDS-186B	BU 50510	G186	6	1/8	15	44	14	H-x18B
RDS-146B	BU 50510	G146	6	1/4	17	50	18	H-x14B
RDS-188B	BU 50510	G188	8	1/8	15	48	14	H-x18B
RDS-148B	BU 50510	G148	8	1/4	17	52	18	H-x14B

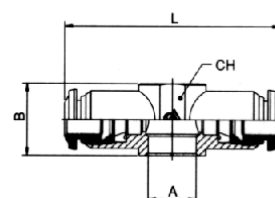

Škrťící ventily s tlumičem hluku / Choking Valves with Silencer

Řada SVL / SVL Series



Použití Use	slouží pro řízení rychlosti pohybu pneumatických válců škrcením průtoku vzduchu s následným tlumením hluku na odfuku z ventilu Serve to control speed of motion of pneumatic cylinders by choking the air flow with subsequent sound damping at valve venting
Konstrukce ventilů Construction of valves	škrťící ventil s tlumičem hluku Choking valve with sound damper
Konstrukční materiály Construction material	mosaz, spékáný bronz, nerez ocel, NBR Brass, sintered bronze, stainless steel, NBR
Pracovní poloha Working position	libovolná, s možností montáže přímo na odfuk ventilu Any, with option of mounting directly on valve venting
Pracovní rozsah tlaku Working pressure range	0,2 ÷ 1,2 MPa 0,2 ÷ 1,2 MPa
Rozsah teplot Temperature range	-10°C ÷ +80°C, při použití pod bodem mrazu nutno zabránit vzniku ledových částic -10°C ÷ +80°C, when used below zero, it is necessary to prevent forming of ice particles
Pracovní médium Working medium	stlačený vzduch tř. 5 dle ČSN ISO 8573-1 Compressed air Class 5 according to ČSN ISO 8573-1

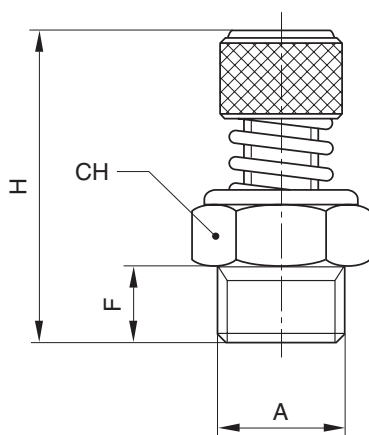

Schematická značka Schematic symbol	Typ Type	Obj. číslo Order No.	Max. průtok Q_{max} Max. flow Q_{max} $Ndm^3 \cdot min^{-1}$	A	F mm	H_{min} mm	H_{max} mm	CH mm	Hmotnost kg Weight in kg
	SVL-1/8	BU 7050 G18	160	G1/8"	6	26	28	13	0,015
	SVL-1/4	BU 7050 G14	420	G1/4"	8	30	32	15	0,025
	SVL-3/8	BU 7050 G38	750	G3/8"	10	35	38	22	0,06
	SVL-1/2	BU 7050 G12	800	G1/2"	10	36	39	22	0,09

Rychloodvětrávací ventil / High-speed Venting Valve

Řada ROV / ROV Series



Použití Use	slouží pro rychlé odvětrání pneumatických válců Serves for high-speed venting of pneumatic cylinders
Konstrukce ventilů Construction of valves	sedlový ventil Seat valve
Konstrukční materiály Construction material	mosaz OT 58 UNI 5705 (CuZn40Pb2) galvanicky poniklována, NBR 70, nylon PA6 OT 58 UNI 5705 brass (CuZn40Pb2), nickel plated, NBR 70, PA6 Nylon
Pracovní poloha Working position	libovolná Any
Pracovní rozsah tlaku Working pressure range	0,3 ÷ 1 MPa 0,3 ÷ 1 MPa
Rozsah teplot Temperature range	-18°C ÷ +70°C -18°C ÷ +70°C
Pracovní médium Working medium	stlačený vzduch tř. 5 dle ČSN ISO 8573-1 Compressed air Class 5 according to ČSN ISO 8573-1

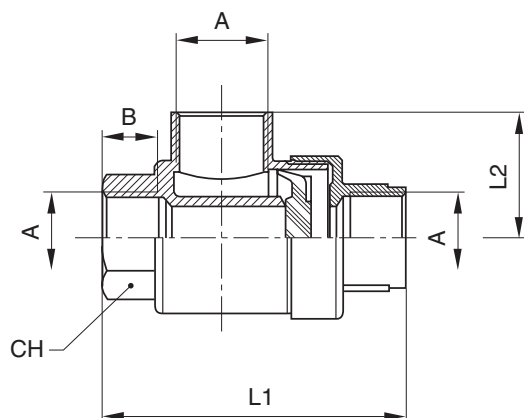

Schematická značka Schematic symbol	Typ Type	Objednací číslo Order No.	Jmen. průtok QN Nominal QN flow Ndm ³ .min ⁻¹	A	B mm	CH mm	L ₁ mm	L ₂ mm	Hmotnost kg Weight in kg
	ROV-M5	BU 6050 M5	110	M5	4	10	25	10	0,06
	ROV-1/8	BU 6050 G18	800	G 1/8"	8,5	15	42	19,5	0,088
	ROV-1/4	BU 6050 G14	1 670	G 1/4"	11	19	54	25	0,143
	ROV-3/8	BU 6050 G38	1 720	G 3/8"	12	22	60,5	26,5	0,168
	ROV-1/2	BU 6050 G12	4 500	G 1/2"	15	26	71	32	0,334
	ROV-3/4	BU 6050 G34	10 750	G 3/4"	18,5	32	87	37	0,79
	ROV-1	BU 6050 G1	10 750	G 1"	19	46	109	48	0,79

Logické členy „AND“ „OR“ Logic Members „AND“ „OR“



Použití Use	členy pro logické funkce Members for logical functions
Konstrukce ventilů Construction of valves	sedlové ventily Seat valves
Konstrukční materiály Construction material	mosaz OT 58, NBR, nerez ocel, hliník 11S OT 58 brass, NBR, stainless steel, 11S aluminum
Pracovní poloha Working position	libovolná Any
Pracovní rozsah tlaku Working pressure range	0,2 ÷ 1 MPa 0,2 ÷ 1 MPa
Rozsah teplot Temperature range	0°C ÷ +60°C 0°C ÷ +60°C
Pracovní médium Working medium	stlačený vzduch tř. 5 dle ČSN ISO 8573-1 Compressed air Class 5 according to ČSN ISO 8573-1
Doporučené hadice Recommended hoses	plastové hadičky PE, PA, PTFE, vnější průměr 4 mm PE, PA, PTFE plastic hoses, external diameter of 4 mm

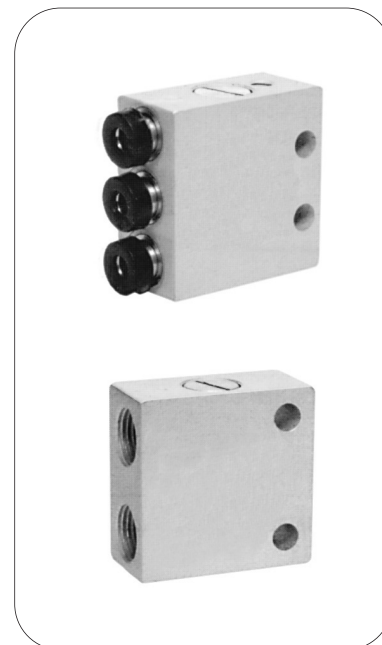

A 08.021.4
A 08.025.4

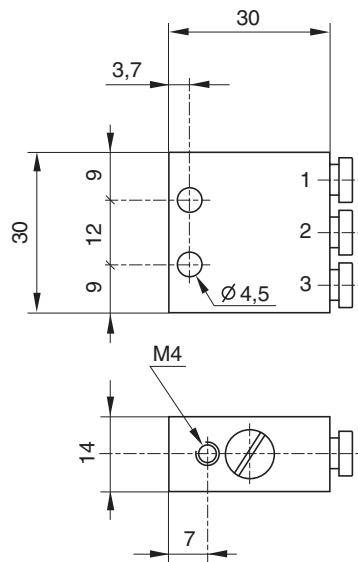

A 08.023.4
A 08.027.4

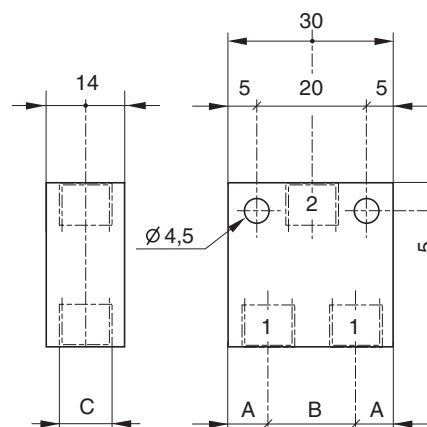

Schematická značka Schematic symbol	Typ Type	Obj. číslo Order No.	Jmen. průtok QN Nominal QN flow Ndm ³ .min ⁻¹	A mm	B mm	připojení C Connection C	Hmotnost kg Weight in kg
	OR	A08.021.4	100	-	-	hadička / hose Ø 4 mm	0,06
	OR	A08.023.4	100	7	16	G 1/8"	0,06
	AND	A08.025.4	100	-	-	hadička / hose Ø 4 mm	0,06
	AND	A08.027.4	100	7	16	G 1/8"	0,06

Zpětné ventily / Reverse Valves

Řada ZVH / ZVH Series



Použití Use	použití jako jednosměrný ventil Use as single-direction valve
Konstrukce ventilů Construction of valves	jednosměrný ventil zatěžovaný pružinou Single-direction valve spring-loaded
Konstrukční materiály Construction material	poniklovaná mosaz, nerez ocel, NBR Nickel plated brass, stainless steel, NBR
Pracovní poloha Working position	libovolná Any
Pracovní rozsah tlaku Working pressure range	0,2 ÷ 1 MPa 0,2 ÷ 1 MPa
Rozsah teplot Temperature range	-18°C ÷ +70°C -18°C ÷ +70°C
Pracovní médium Working medium	stlačený vzduch tř. 5 dle ČSN ISO 8573-1 Compressed air Class 5 according to ČSN ISO 8573-1

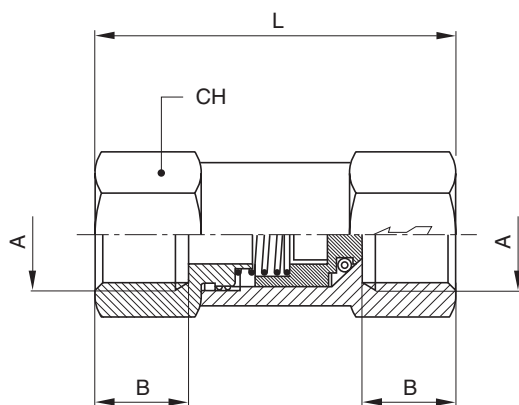

Schematická značka Schematic symbol	Typ Type	Objednací číslo Order No.	Jmen. průtok QN [N.dm ³ .min ⁻¹] Nominal QN flow [N.dm ³ .min ⁻¹]	A mm	B mm	L mm	CH mm	Hmotnost kg Weight in kg
	ZVH-M5	BU 6062 M5	100	M5	5,5	26,5	8	0,10
	ZVH-1/8	BU 6062 G18	630	G1/8"	8,5	35,5	13	0,12
	ZVH-1/4	BU 6062 G14	1 050	G1/4"	11	42,5	17	0,18
	ZVH-3/8	BU 6062 G38	3 050	G3/8"	12	58	24	0,19
	ZVH-1/2	BU 6062 G12	3 050	G1/2"	15	64	24	0,18

Zpětné ventily / Reverse Valves

Řada ZVHS / ZVHS Series



Jednosměrný ventil – nástrčné provedení - řada ZVHS / Single-direction valve – Socket Type - ZVHS Series

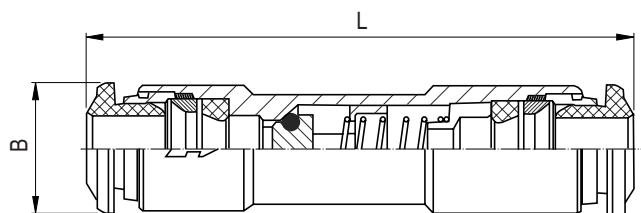

Schematická značka Schematic symbol	Typ Type	Objednací číslo Order No.	Hadička mm	L mm	B mm
	ZVHS-4	BU 6064 – 4	4	44,5	10
	ZVHS-6	BU 6064 – 6	6	52	12,5
	ZVHS-8	BU 6064 – 8	8	56	14

Přesuvné ventily 3/2 s odfukem - řada HS / Reversing Valves 3/2 with exhaust - HS Series

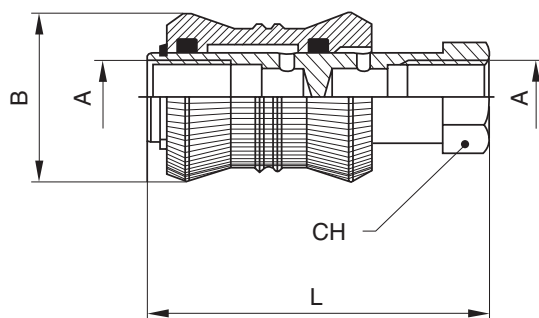

Schematická značka Schematic symbol	Typ Type	Objednací číslo Order No.	A mm	B mm	L mm	CH mm	Hmotnost kg Weight in kg
	HS 18 B	BU 6060 – 18	G1/8"	25	48	14	0,05
	HS 14 B	BU 6060 – 14	G1/4"	30	58	17	0,07
	HS 38 B	BU 6060 – 38	G3/8"	35	68	22	0,09
	HS 12 B	BU 6060 – 12	G1/2"	40	80	27	0,11

Blokační ventil jednosměrný

Block valve unidirectional coupling



Použití Use	slouží pro zablokování pohybu válce při výpadku (poruše) stlačeného vzduchu it serves for locking the cylinder in case of taking away the feeding (for example in case of emergency)
Konstrukční materiály Construction material	mosaz OT 58 UNI 5705 galvanicky poniklována, polyacetalová pryskyřice, nerez ocel OT 58 UNI 5705 brass (CuZn40Pb2), nickel plated, polyacetal resin, stainless steel
Pracovní poloha Working position	libovolná Any
Jmenovitý přetlak PN Nominal overpressure PN	0,6 MPa 0,6 MPa
Pracovní rozsah tlaku Working pressure range	0,3 ÷ 1 MPa 0,3 ÷ 1 MPa
Teplota okolí Surrounding environment temperature	-20°C ÷ + 80°C -20°C ÷ + 80°C
Pracovní médium Working medium	stlačený vzduch tř.5 dle ČSN 8573-1 compressed air class 5 according to ČSN 8573-1

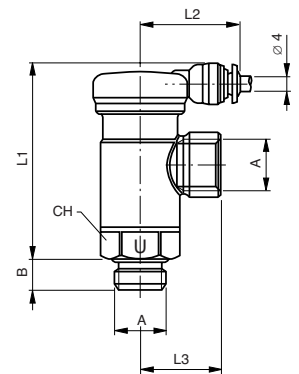

Schematická značka Schematic symbol	Typ Type	Objednací číslo Order No.	Jmen. průtok QN [N.dm ³ .min ⁻¹] Nominal QN flow [N.dm ³ .min ⁻¹]	A	B	L1	L2	L3	CH
	VBU-18	BU 8880 1/8	750	1/8	6	50	25	18,5	18
	VBU-14	BU 8880 1/4	1420	1/4	8	50,5	25	20,5	18

Válec v pohybu / Cylinder in action

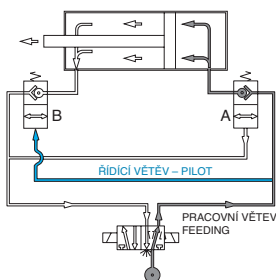

Plnění blokačního ventilu A a pilotního ventilu B umožňuje pohyb pístu v jednom směru.
Plnění blokačního ventilu B a pilotního ventilu A umožňuje pohyb pístu v opačném směru.

Feeding the block valve A and the pilot B you allow the movement of the piston in one direction.

Feeding the block valve B and the pilot A you allow the movement of the piston in the opposite direction.

Válec zablokován / Stopped Cylinder

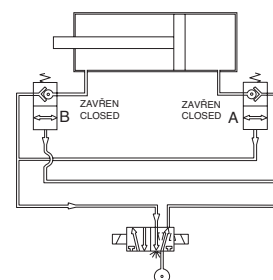

Odstranění plnění (přerušení napájení) uvnitř řídicí větve (např. v případě nouzové události) blokační ventil uzamkne válec v pozici, ve které se nachází v okamžiku vzniku této události a to i v případě, kdy je píst zatížen.

Taking away the feeding within the pilot circuit (for example in case of emergency) the block valves lock the cylinder into the position where it is at that moment, even if at the piston are attached some loads.

Zapojení / Instalation

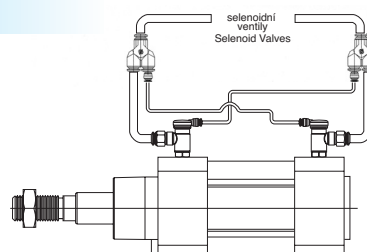

Blokační ventil dvousměrný

Block valve bidirectional coupling



Použití	slouží pro zablokování pohybu válce při výpadku (poruše) stlačeného vzduchu, umožňuje také řízené zablokování pohybu válce it serves for the locking of a cylinder motion in case of pressure air failure, controlled locking of a cylinder motion is available too
Konstrukční materiály Construction material	mosaz OT 58 UNI 5705 galvanicky poniklována, polyacetalová pryskyřice, nerez ocel OT 58 UNI 5705 brass (CuZn40Pb2), nickel plated, polyacetal resin, stainless steel
Pracovní poloha Working position	libovolná Any
Jmenovitý přetlak PN Nominal overpressure PN	0,6 MPa 0,6 MPa
Pracovní rozsah tlaku Working pressure range	0,3 ÷ 1 MPa 0,3 ÷ 1 MPa
Teplota okolí Surrounding environment temperature	-20°C ÷ + 80°C -20°C ÷ + 80°C
Pracovní médium Working medium	stlačený vzduch tř. 5 dle ČSN ISO 8573-1 Compressed air Class 5 according to ČSN ISO 8573-1

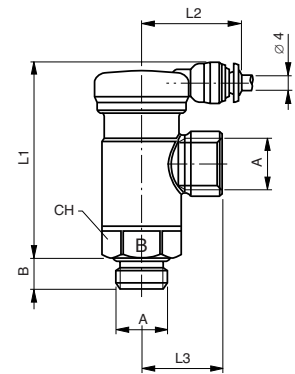

Schematická značka Schematic symbol	Typ Type	Objednací číslo Order No.	Jmen. průtok QN [N.dm ³ .min ⁻¹] Nominal QN flow [N.dm ³ .min ⁻¹]	A	B	L1	L2	L3	CH
	VBB-18	BU 8890 1/8	750	1/8	6	50	25	18,5	18
	VBB-14	BU 8890 1/4	1420	1/4	8	50,5	25	20,5	18

Válec v pohybu / Cylinder in action

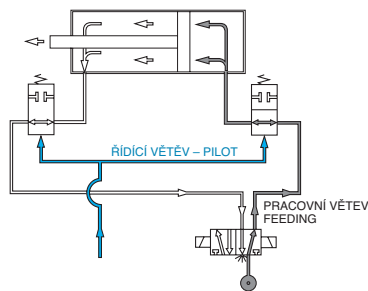

Řídicí větev a pracovní větev válce jsou nezávislé. Napájením řídicí větve blokační ventily umožňují střídavý pohyb válce.

The driving circuit and the feeding circuit of the cylinder are independent. Feeding the driving circuit the block valves allow the alternate movement of the cylinder.

Válec zablokován / Stopped Cylinder

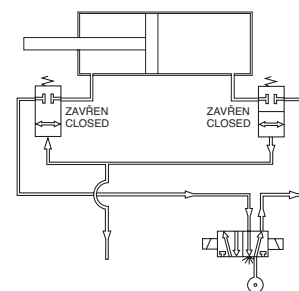

Při odstranění plnění do řídicí větve blokační ventily uzamknou válec v pozici, ve které se nachází v okamžiku vzniku této události a to i v případě, že na píst působí zatížení.

Taking away the feeding to the pilot circuit the block valves lock the cylinder into the position where it is at that moment, even if at the piston are attached some loads.

Zapojení / Instalation

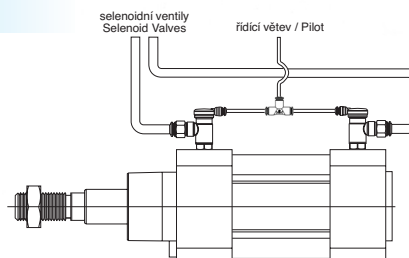

OSCILAČNÍ VENTILY / OSCILLATION VALVES

Typ / Obj. č. Type / Order No.	Připojovací rozměr Connection dimension	Pracovní rozsah Working range	Jmenovitý průtok Nominal flow	Objednávací číslo Order No.
S9 568 / 68 - 1/4 - SO	G 1/4"	0,25–0,8 MPa	1 300N.dm ³ .min ⁻¹	PD 34796

ČASOVĚ ZPOŽDĚNÝ VENTIL (TIMER)

Typ / Obj. č. Type / Order No.	Připojovací rozměr Connection dimension	Pracovní rozsah Working range	Jmenovitý průtok Nominal flow	Objednávací číslo Order No.
T3P 10 - NG 10	NG	1–10 s		KY 8103
T3P 10 - NG 40	NG	5–40 s		KY 8104
T3P 10 - NO 06	NO	0,5–6 s		KY 8105
T3P 10 - NO 25	NO	2,5–25 s		KY 8105

VENTILY PRO DVOURUČNÍ SPOUŠTĚNÍ / VALVES FOR TWO-HANDED ACTIVATION

Typ / Obj. č. Type / Order No.	Připojovací rozměr Connection dimension	Pracovní rozsah Working range	Jmenovitý průtok Nominal flow	Objednávací číslo Order No.
S9 563 / 65 - 1/4 - SO	G 1/4"	0–1 MPa	1 300N.dm ³ .min ⁻¹	PD 37173
A 08.156.4	G 1/8"	0,2–0,8 MPa	100N.dm ³ .min ⁻¹	A 08.156.4

A 08.156.4



schéma zapojení application sketch



Tlumiče hluku / Sound Dampers

Řada TH, TP / TH, TP Series

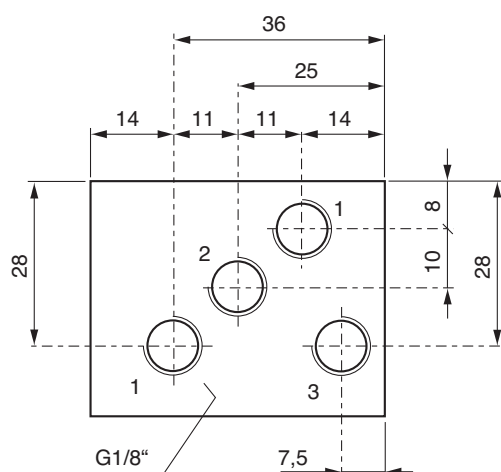
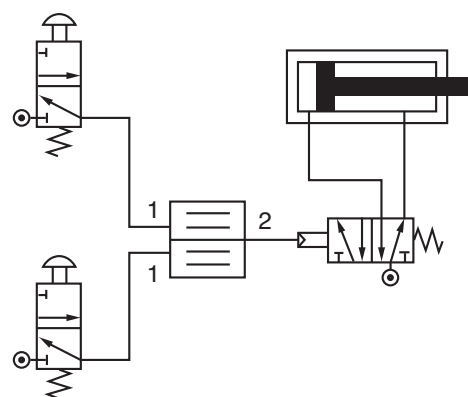

Použití Use	slouží pro utlumení hluku vzduchu vytékajícího z pneumatických soustav do atmosféry Serve as a sound damper of air coming out from pneumatic systems into the atmosphere
Konstrukce tlumičů Construction of silencers	jednokomorový kompaktní tlumič hluku Single-chamber compact sound damper
Konstrukční materiály Construction material	mosaz, spěkaný bronz Brass, sintered bronze
Pracovní poloha Working position	libovolná Any
Pracovní rozsah tlaku Working pressure range	0 ÷ 1,2 MPa 0 ÷ 1,2 MPa
Teplota okolí Surrounding environment temperature	-10°C ÷ + 80°C, při použití pod bodem mrazu nutno zabránit vzniku ledových částic -10°C ÷ + 80°C, when used below zero, it is necessary to prevent forming of ice particles
Pracovní médium Working medium	stlačený vzduch tř. 5 dle ČSN ISO 8573-1 Compressed air Class 5 according to ČSN ISO 8573-1



TH

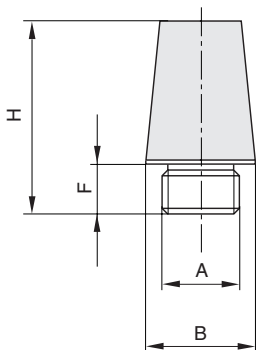

Schematická značka Schematic symbol	Typ Type	Obj. číslo Order No.	A	B mm	F mm	H mm	Hmotnost kg Weight in kg
	TH 4	AI700018	G1/8"	12	6	21	0,006
	TH 6	AI700014	G1/4"	15	6	25	0,012
	TH 10	AI700038	G3/8"	19	8	36	0,032
	TH 15	AI700012	G1/2"	23	10	43	0,063
	TH 20	AI700034	G3/4"	30	13	53	0,098
	TH 25	AI700010	G1"	37	15	63	0,120

TP

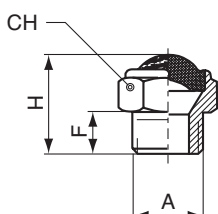

Schematická značka Schematic symbol	Typ Type	Obj. číslo Order No.	F mm	H mm	CH mm	Hmotnost kg Weight in kg
	TP 1/8	BU 7020 G18	6	16	13	0,006
	TP 1/4	BU 7020 G14	8	19	16	0,012
	TP 3/8	BU 7020 G38	9	21	19	0,032
	TP 1/2	BU 7020 G12	10	23	24	0,063